



BENDINI

alumínios

A EMPRESA

Bendini Alumínios é uma empresa que surgiu com o objetivo de revolucionar o mercado, trazendo soluções para os serralheiros e vidraceiros.

Contamos com uma equipe de profissionais qualificados para melhor lhe atender, garantimos qualidade dos produtos e um atendimento especializado.

Possuímos um estoque a pronta entrega com a melhor solução para a sua obra.



CANTONEIRAS

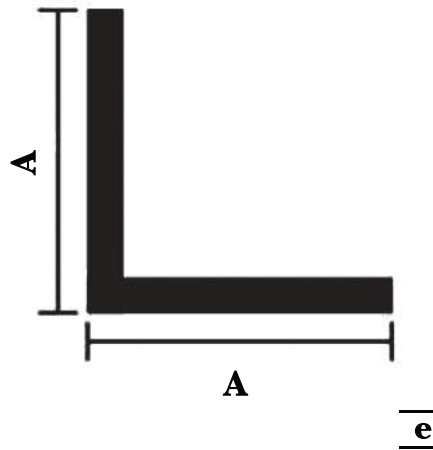

CÓDIGO	MILÍMETROS (mm)		POLEGADAS	PESO
	A	e	A	Kg/BR
CT001	12,7	1,2	1/2	0,6
CT005	15,88	1,2	5/8	0,8
CT007	19,05	1,2	3/4	1
CT016	25,4	1,2	1	1,26
CT019	25,4	3,18	1	2,6
CT021	31,75	1,59	1.1/4	1,45
CT022	31,75	3,18	1.1/4	2,9
CT047	38,1	1,59	1.1/2	2
CT026	38,1	3,18	1.1/2	3,9
CT031	50,8	1,5	2,0	2,2
CT032	50,8	3,18	2	5,1

BARRA CHATA

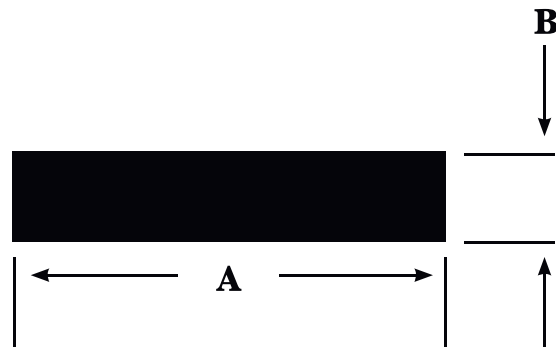

CÓDIGO	MILÍMETROS (mm)		POLEGADAS	PESO
	A	B	A	Kg/BR
BC002	12,7	3,18	1/2	0,7
BC008	15,88	3,18	5/8	0,85
BC009	15,88	4,76	5/8	1,26
BC015	19,05	3,18	3/4	1
BC016	19,05	4,76	3/4	1,5
BC025	25,4	3,18	1	1,35
BC026	25,4	4,76	1	2
BC050	38,1	3,18	1.1/2	2,1
BC060	50,4	3,18	2	2,7

TUBO REDONDO

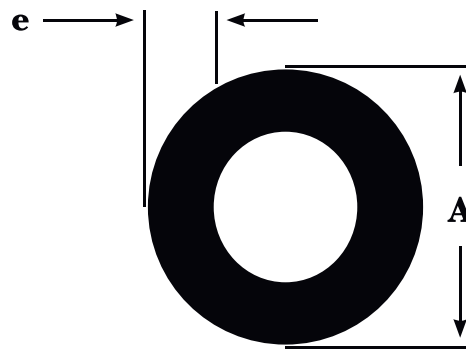

CÓDIGO	MILÍMETROS (mm)		POLEGADAS	PESO
	A	e	A	Kg/BR
TR002	9,53	1,58	3/8	0,7
TR005	12,7	1,58	1/2	1
TR012	15,88	1,2	5/8	0,9
TR018	19,05	0,8	3/4	0,73
TR039	25,4	1	1	1,3
TR055	31,75	1,58	1.1/4	2,5
TR070	38,1	1,58	1.1/2	3,1
TR098	50,8	1,58	2	4,2
TR133	76,2	1,58	3	5,9

TUBO QUADRADO

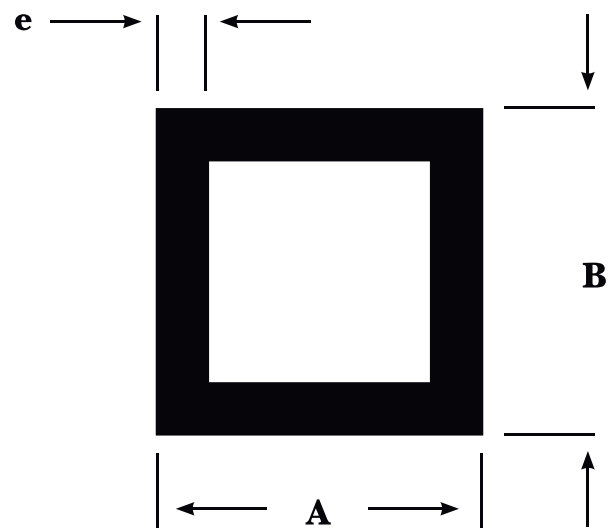

CÓDIGO	MILÍMETROS (mm)		POLEGADAS	PESO
	A	B	A	Kg/BR
TQ023	25,4	0,9	1	1,3
TQ013	38,1	0,8	1.1/2	2
TQ017	50,8	1,5	2	4
TQ034	101,6	2	4	10,5
TQ017R	50,80	2	2	6,35
TQ034R	102,60	2,20	4,03	14,25

TUBO RETANGULAR

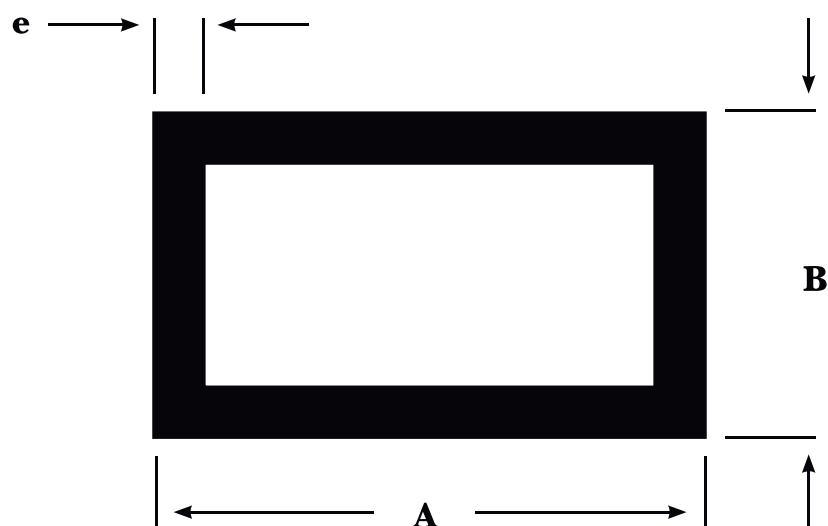

CÓDIGO	MILÍMETROS (mm)			PESO
	A	B	e	Kg/BR
TG001	25,4	12,7	0,80	0,9
TG004	50,8	12,7	1,20	2,4
TG073	50,8	25,4	0,80	2
TG205	76,2	25,4	1,20	4,2
TG014	76,2	38,1	1,20	4,7
TG072	101,6	50,8	1,3	6,4
TG075	152,4	50,8	1,60	10
TG001R	25,40	12,7	1,00	1,2
TG073R	50,8	25,4	1,00	2,5
TG072R	101,6	50,80	2,00	8,7
TG075R	152,4	50,80	3,00	19,50

TUBO RETANGULAR C/ REFORÇO

CÓDIGO	MILÍMETROS (mm)			PESO
	A	B	e	Kg/BR
PC002	50,8	25,4	1,00	2,76
PC004	50,8	38,10	1,00	3,00
PC400	50,8	38,10	1,6	4,6
PC003R	76,20	38,10	1,6	6,35
PC003	76,20	38,10	1,10	4,2

CANTONEIRAS

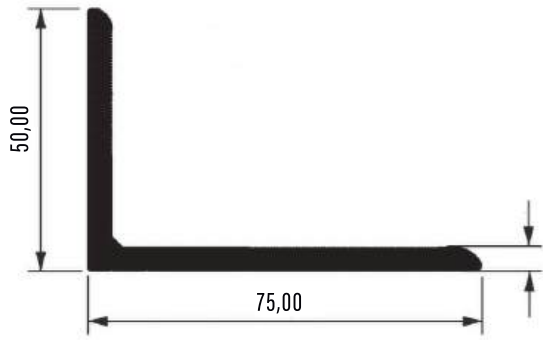

CD004
9 Kg

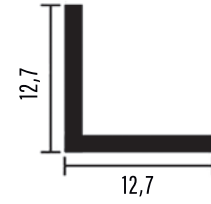

CT001
0,6 Kg

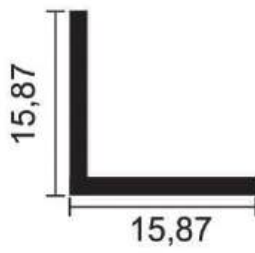

CT005
0,8 Kg

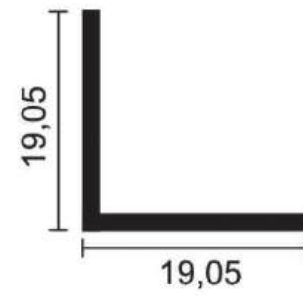

CT007
1 Kg

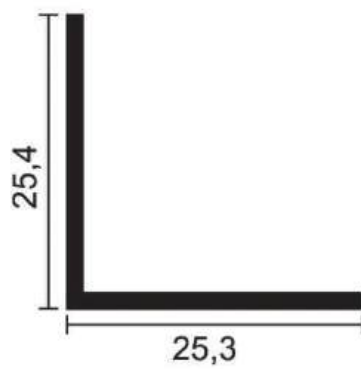

CT016
1,26 Kg

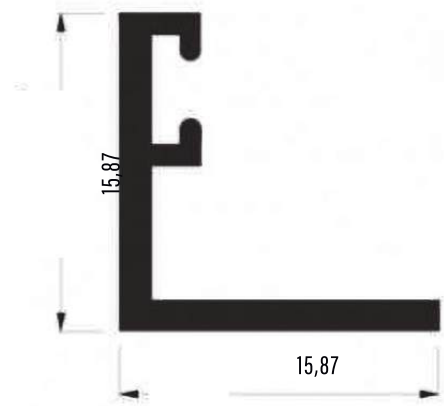

CT229
0,8 Kg

TEMPERADOS 8mm

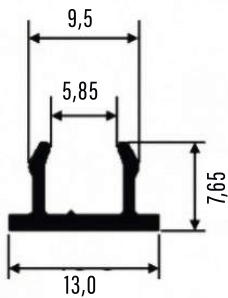

3074
0,5 Kg

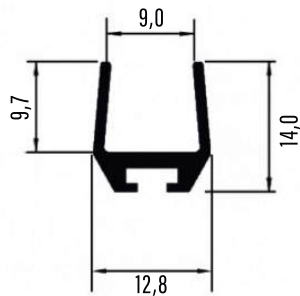

BX022
1,1 Kg

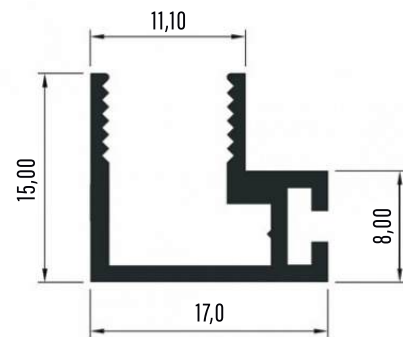

BX023
1,2 Kg

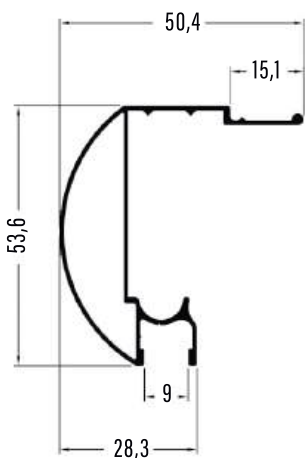

BX060
3,4 Kg

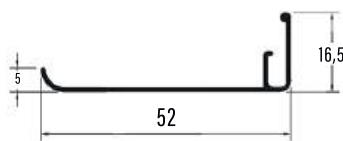

BX061
1,5 Kg

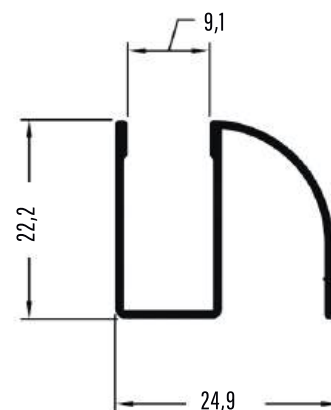

BX062
1,5 Kg

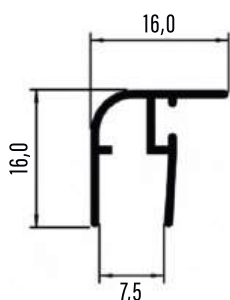

BX063
1,6 Kg

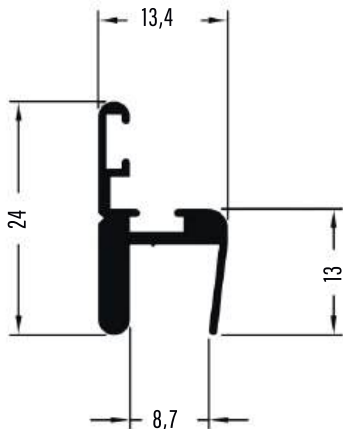

BX099
1,8 Kg

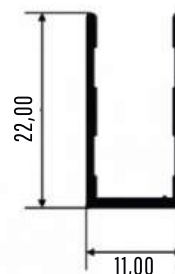

BX103
0,7 Kg

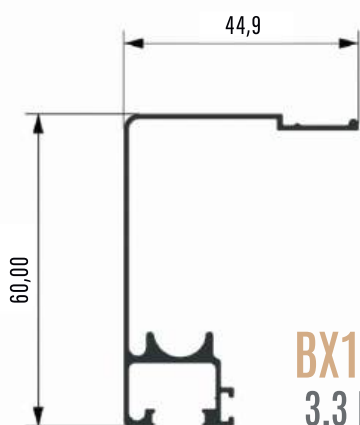

BX118
3,3 Kg

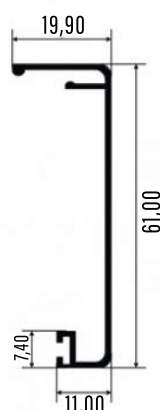

BX119
1,8 Kg

TEMPERADOS 8mm

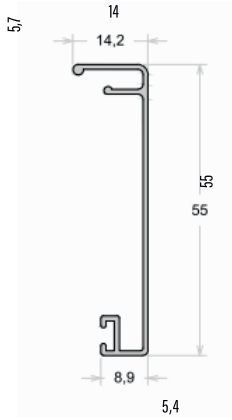

BX122
1,5 Kg

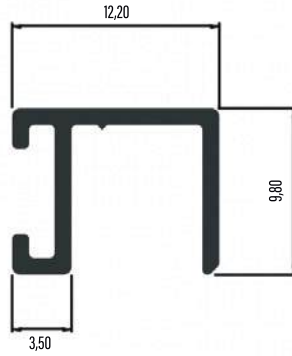

BX126
0,6 Kg

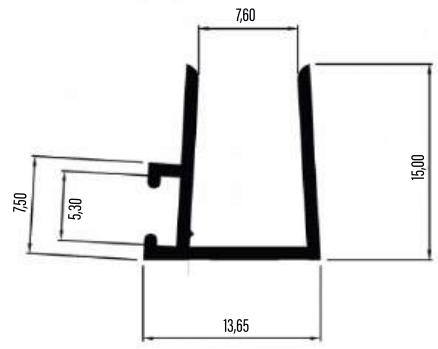

BX128
0,8 Kg

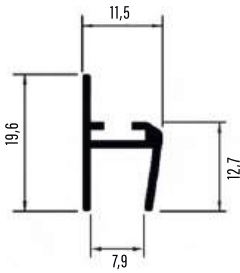

BX130
0,8 Kg

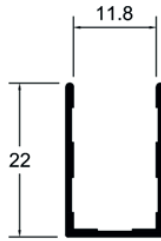

BX137
0,85 Kg

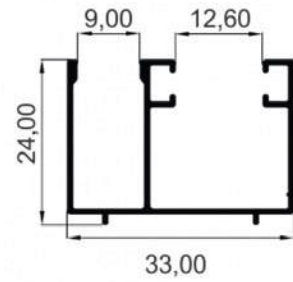

BX164
2 Kg

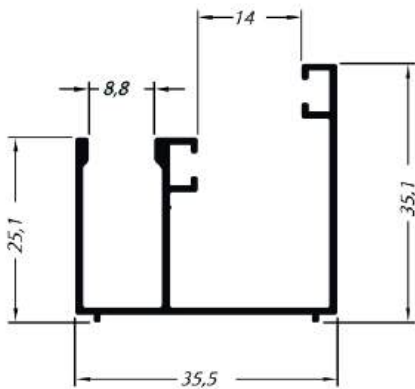

BX165
2,55 Kg

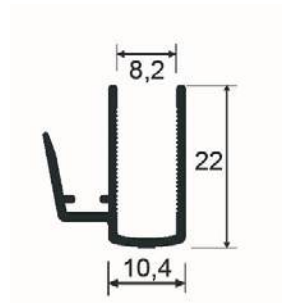

BX252
1,3 Kg



CT229
0,75 Kg

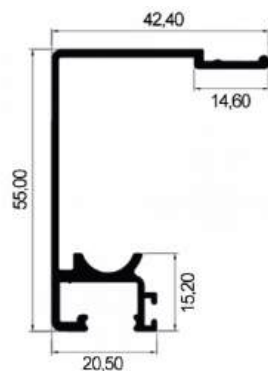

BX121
2,8 Kg

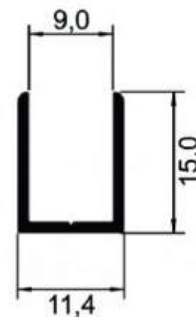

PU044
0,7 Kg

TEMPERADOS 10mm

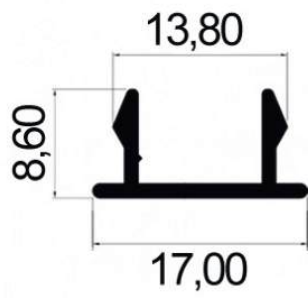

BX029
0,65 Kg

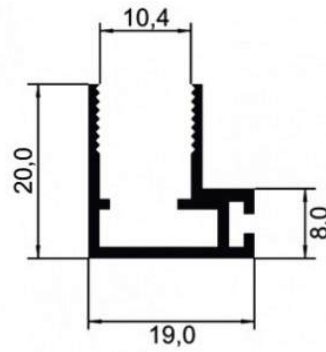

BX030
1,3 Kg

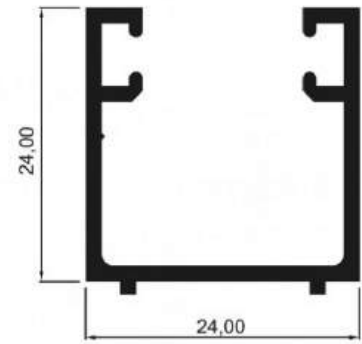

BX054
2 Kg

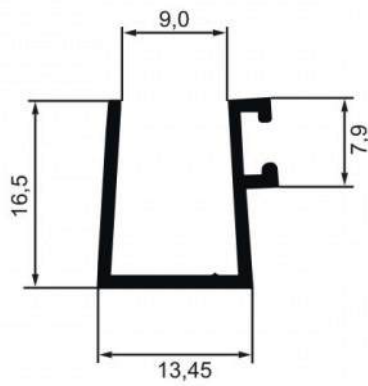

BX056
0,9 Kg

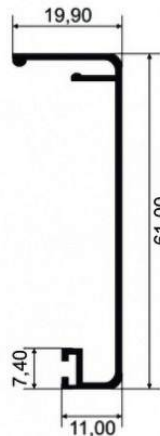

BX119
1,8 Kg

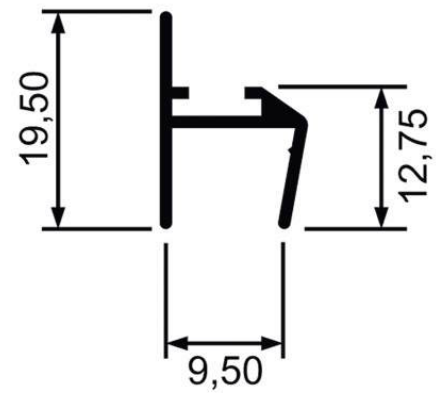

BX131
0,9 Kg

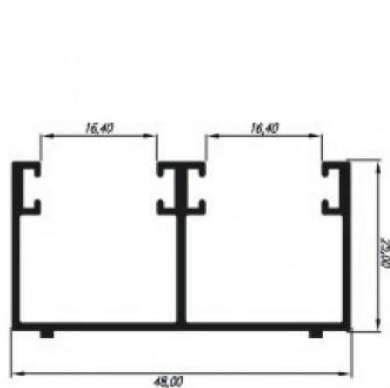

BX170
3 Kg

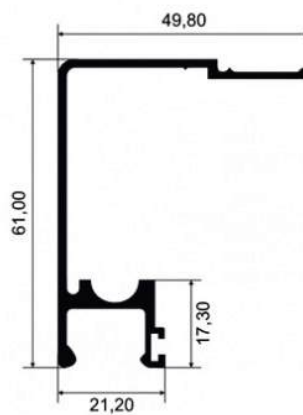

BX180
3,8 Kg

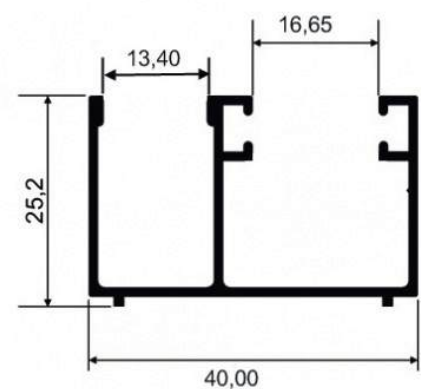

BX182
2,4 Kg

TEMPERADOS 10mm

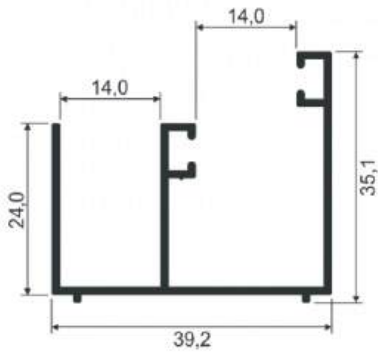

BX183
3,2 Kg

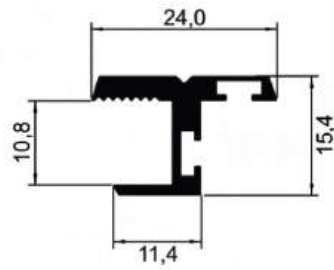

BX209
2 Kg

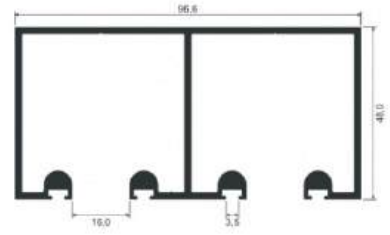

BX248
10,5 Kg

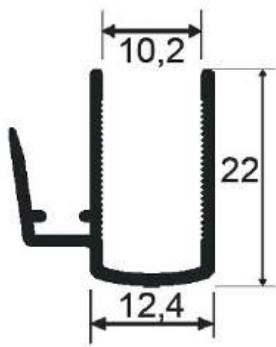

BX253
1,35 Kg

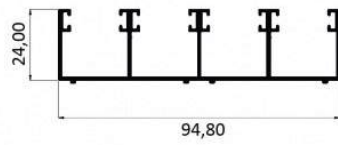

BX266
6,3 Kg

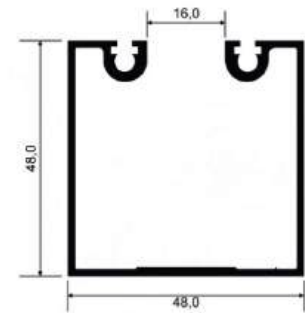

DS1048
5,1 Kg

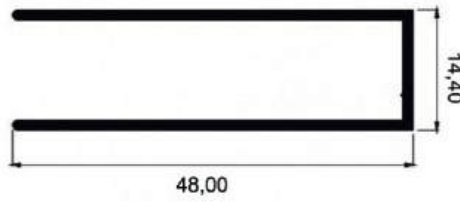

PU520
2,3 Kg

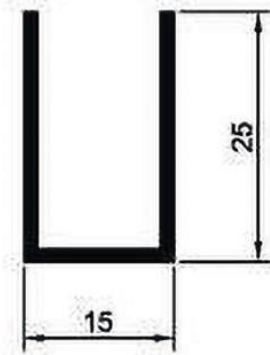

PU40
1 Kg

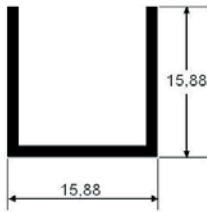

PU004
0,9 Kg

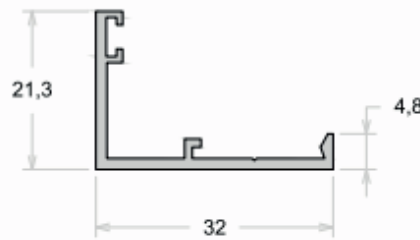

ALO26
1,4 Kg | BR

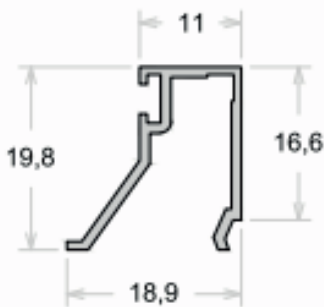

ALO27
1,05 Kg | BR

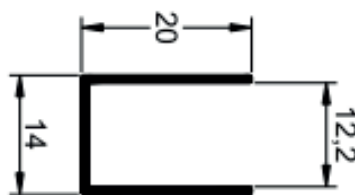

BX609
0,73 Kg | BR

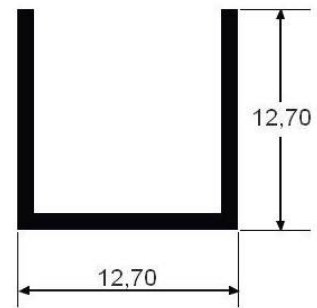

PU002
0,7 Kg | BR

GRADIL

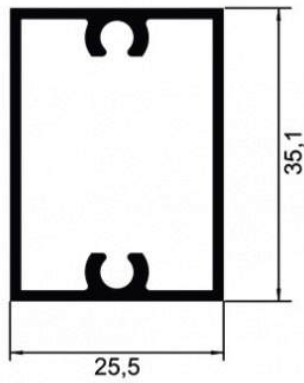

CG012
3 Kg

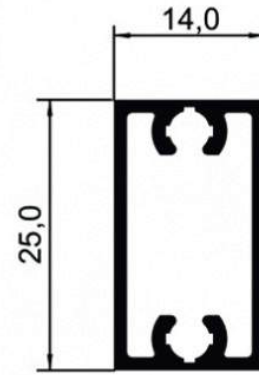

CG021
2,2 Kg

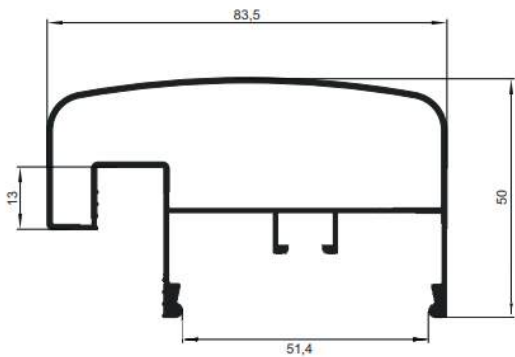

CG063
6,3 Kg

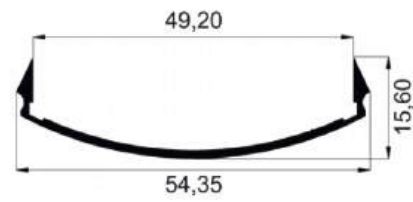

CG074
1,5 Kg

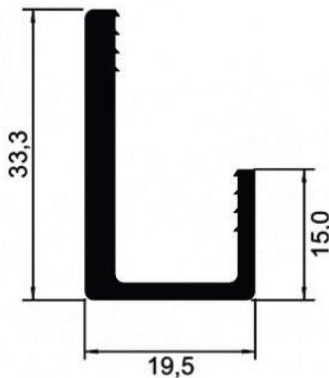

CG075
3,2 Kg

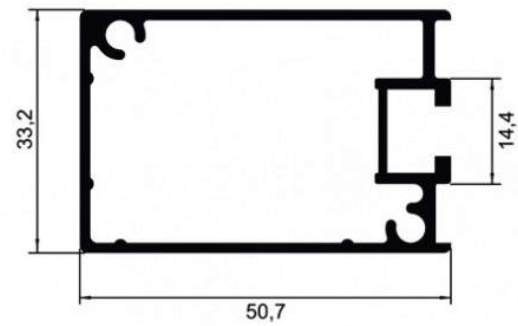

CG077
4,5 Kg

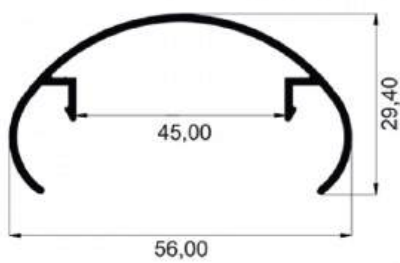

CG078
2,5 Kg

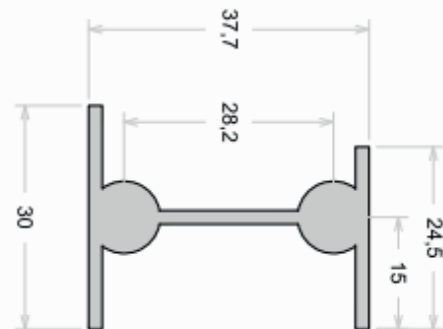

CG076
4,3 Kg

GRADIL

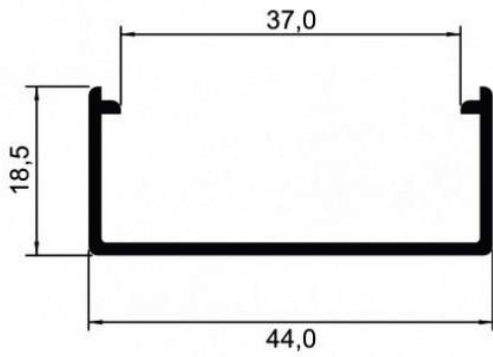

CG079
2,0 Kg

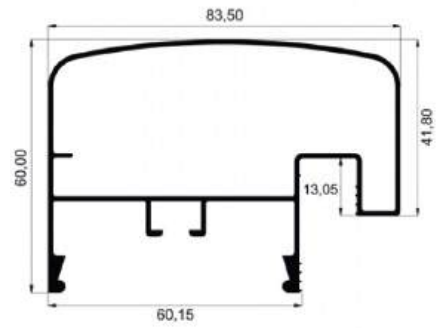

CG830
7,0 Kg

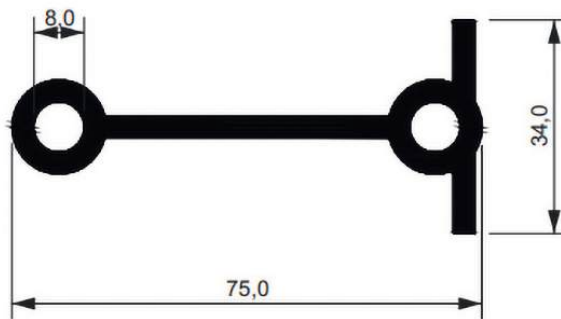

CG834
9,0 Kg

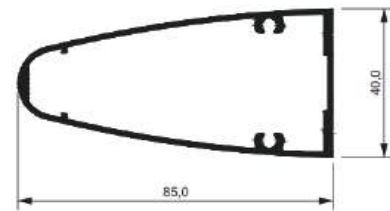

CG833
7,0 Kg

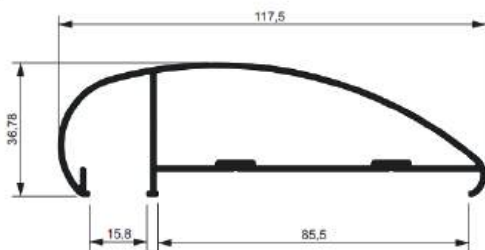

CG885
8,0 Kg

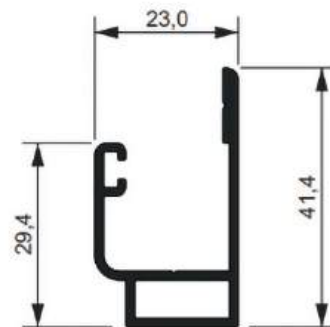

CG887
3,0 Kg

LINHA 25

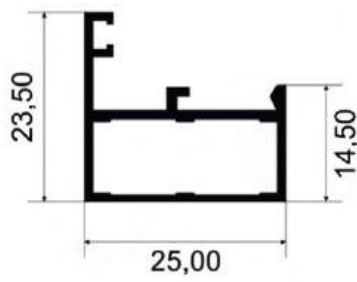

25001
1,7 Kg

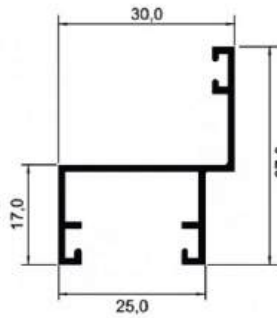

25002
1,9 Kg

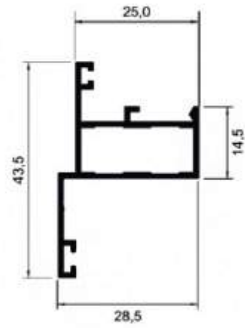

25005
2,3 Kg

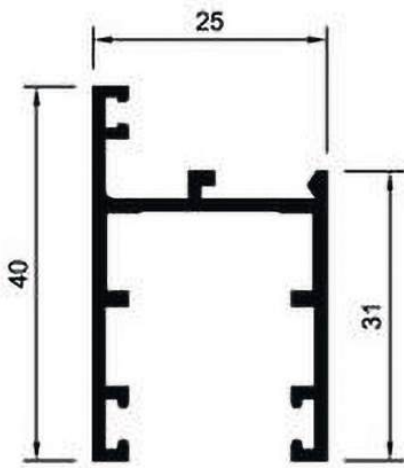

25011
2,4 Kg

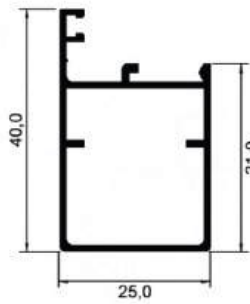

25016
2,5 Kg

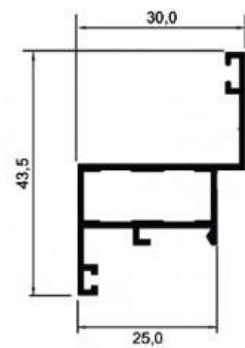

25018
2,8 Kg

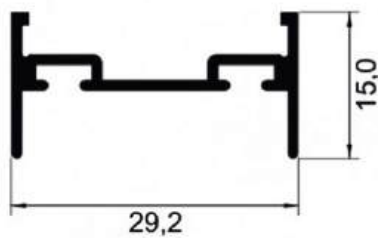

25021
1,45 Kg

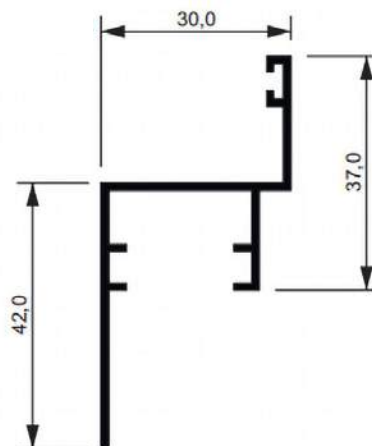

25022
2,3 Kg

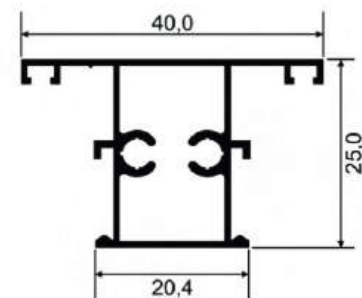

25026
3,05 Kg

LINHA 25

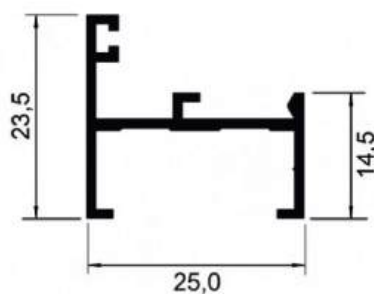

25027
1,7 Kg

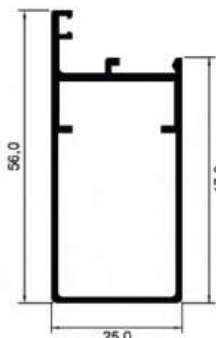

25504
3 Kg

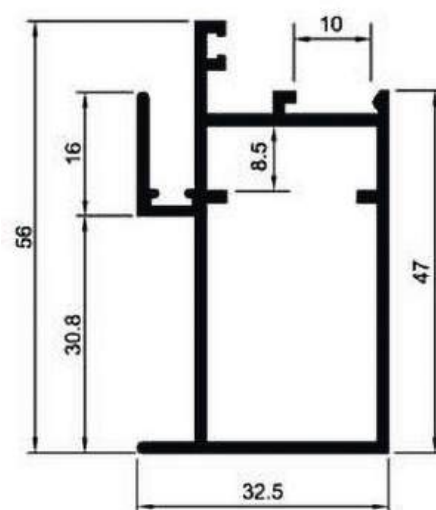

25506
3,5 Kg
4,6 MT/BARRA

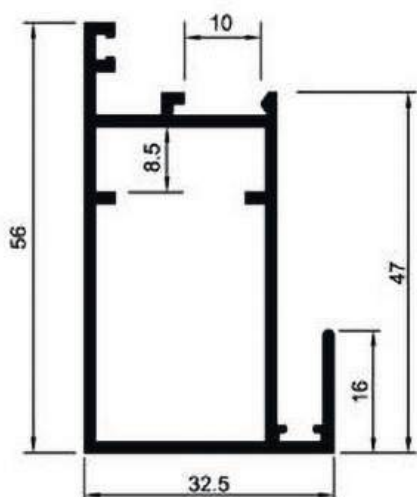

25507
3,4 Kg
4,6 MT/BARRA

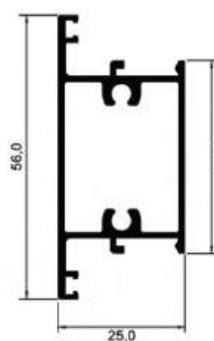

25508
3,5 Kg

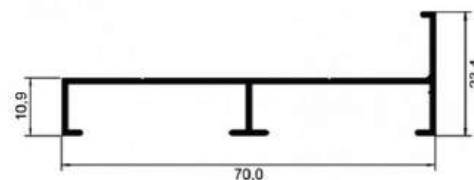

25514
2,6 Kg

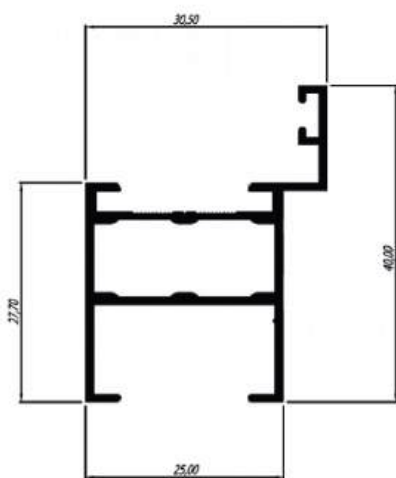

25540
2,7 Kg

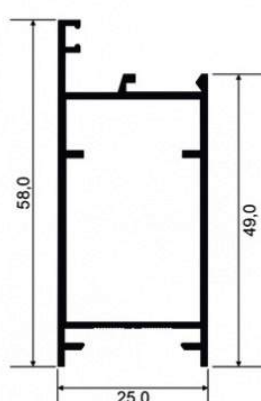

25542
3,7 Kg

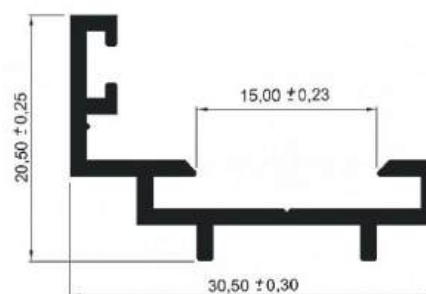

25548
1,5 Kg

LINHA 25

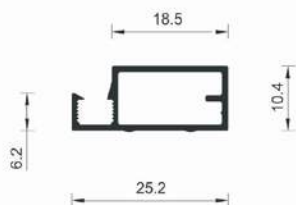

25551
0,95 Kg

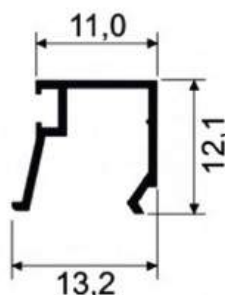

BG001
0,6 Kg

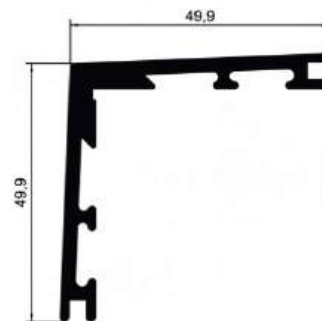

CL006
3,1 Kg
3,00 MT/BARRA

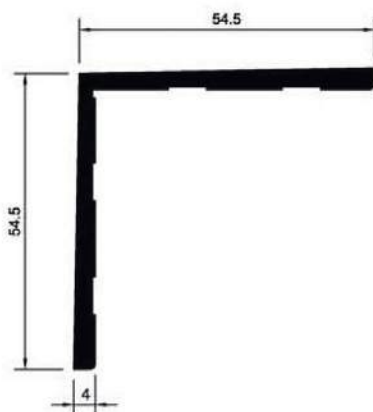

CL007
3 Kg
3,00 MT/BARRA

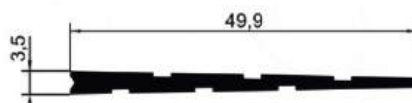

CL011
1 Kg
3,00 MT/BARRA

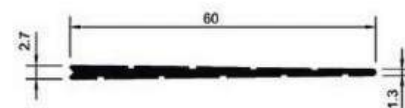

CL036
1 Kg
3,00 MT/BARRA

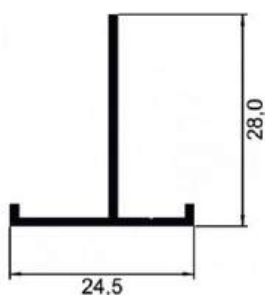

CM008
1,07 Kg

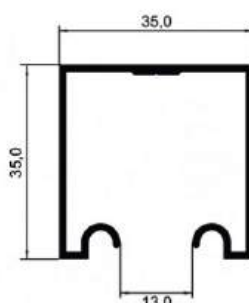

CX1226
2,8 Kg

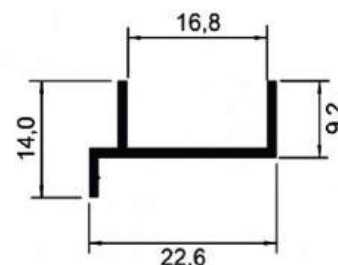

DS036
0,9 Kg

LINHA 25

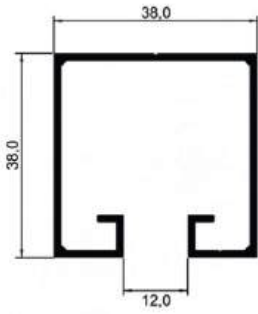

DS152
3,6 Kg

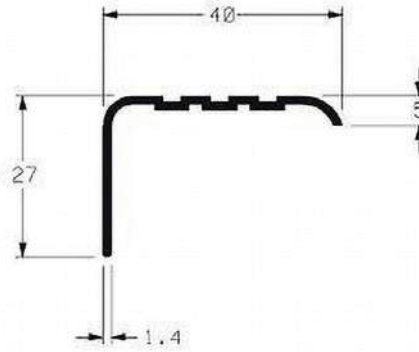

ME013
1,7 Kg

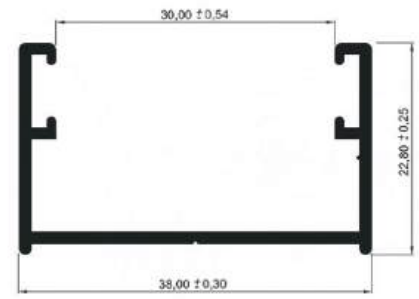

ME024
2,1 Kg

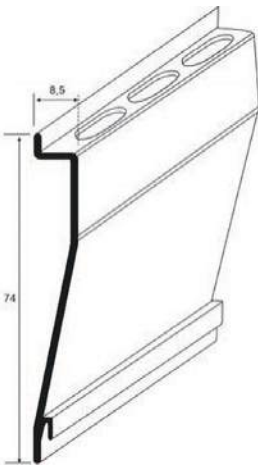

US280
1,6 Kg

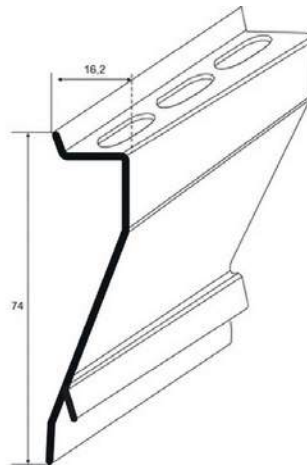

US282
1,85 Kg



VZ023
1,7 Kg

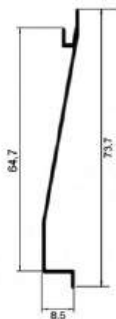

VZ024
1,58 Kg

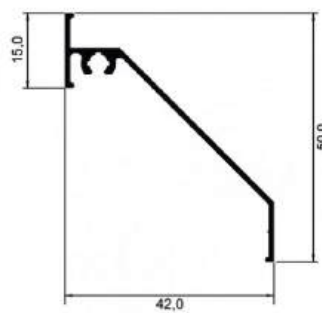

VZ047
1,8 Kg

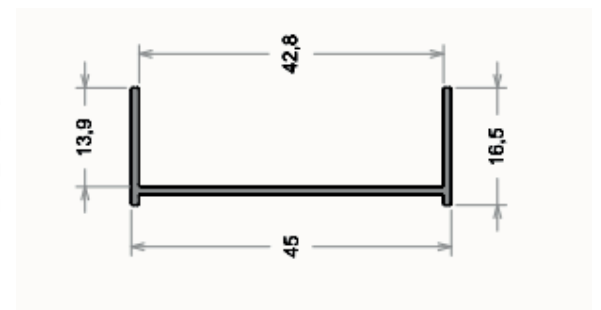

BX113
1,45 Kg

PORTÕES

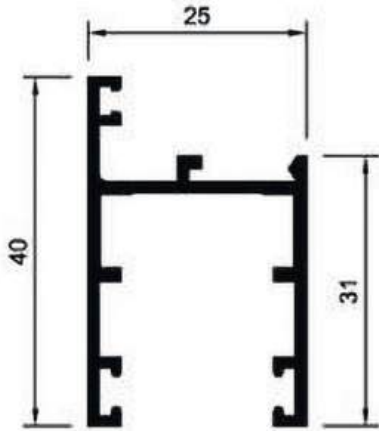

25011
1,6 Kg
BARRA C/ 4 MT

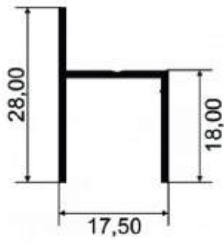

BX106
1,4 Kg - C/ 6 MT
1,0 kg - C/ 4 MT

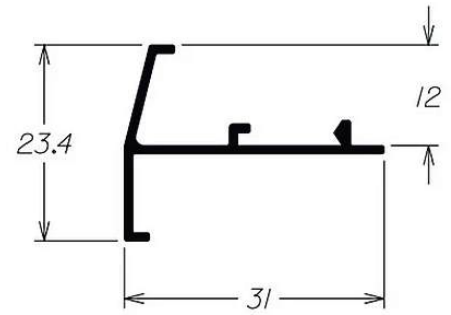

DS290
1,1 Kg

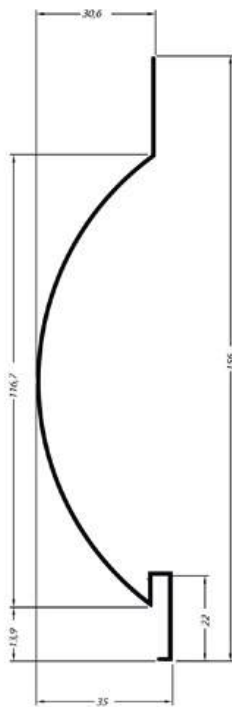

LB038
3,8 Kg - C/ 6 MT
3,2 kg - C/ 5 MT

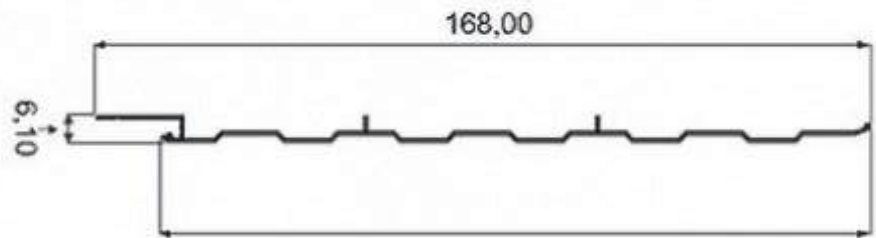

LB050
3,3 Kg

PORTÕES

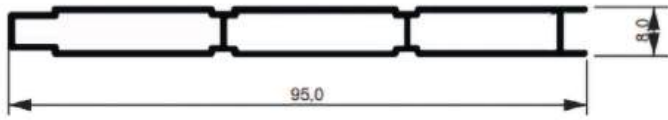

LB060
3 Kg

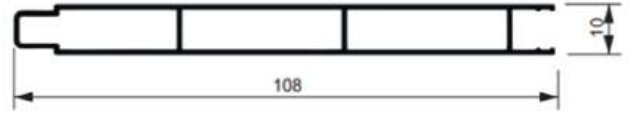

LB061
3,45 Kg

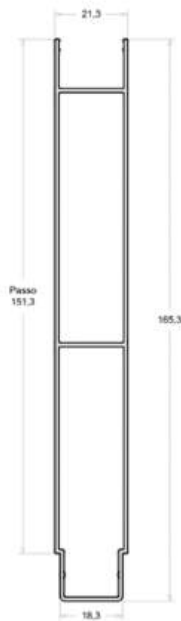

LB080
7,70 Kg

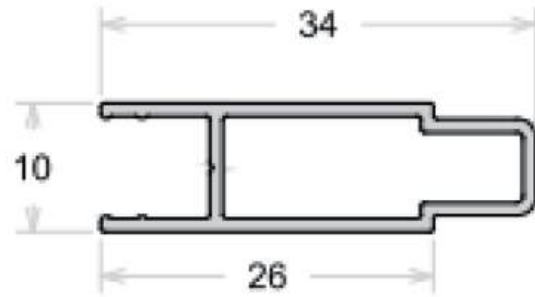

LB063
1,5 Kg

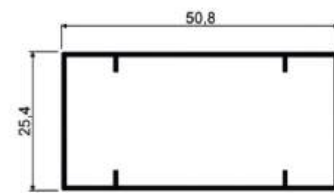

PC002
2,6 Kg

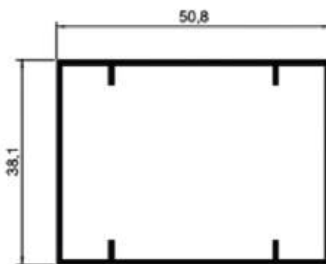

PC004
3,3 Kg

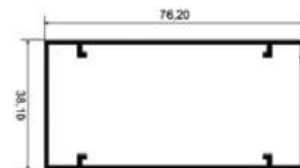

PC003
4,5 Kg

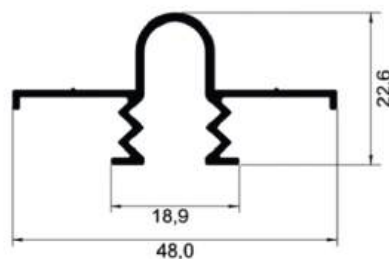

PC006
2,2 Kg

PORTÕES

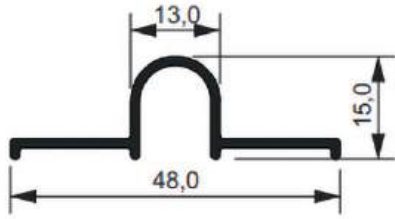

PC007
1,6 Kg

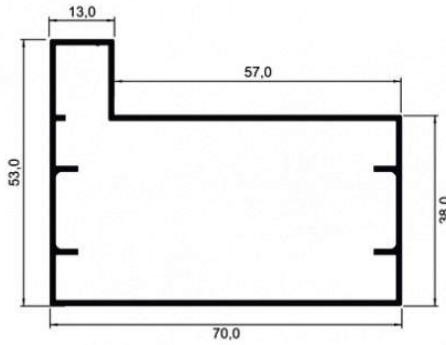

PC010
6 Kg

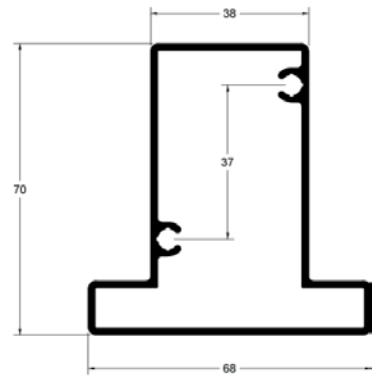

PC011
8,4 Kg

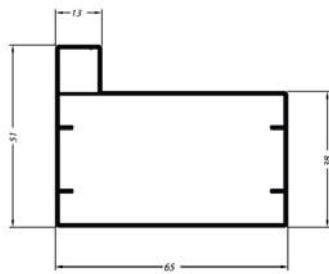

PC012
4,6 Kg

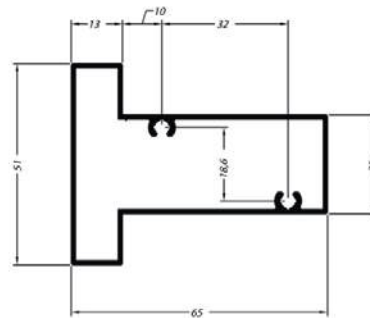

PC013
4,8 Kg

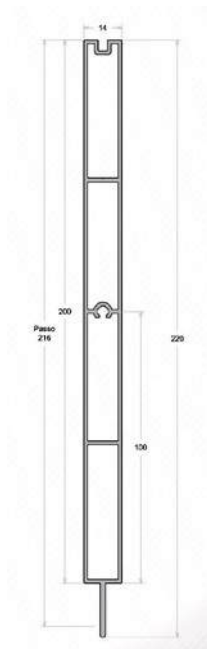

LB030
12,5 Kg

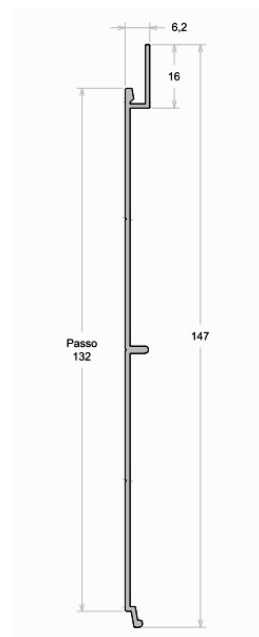

LB036
3 Kg

PORTÕES

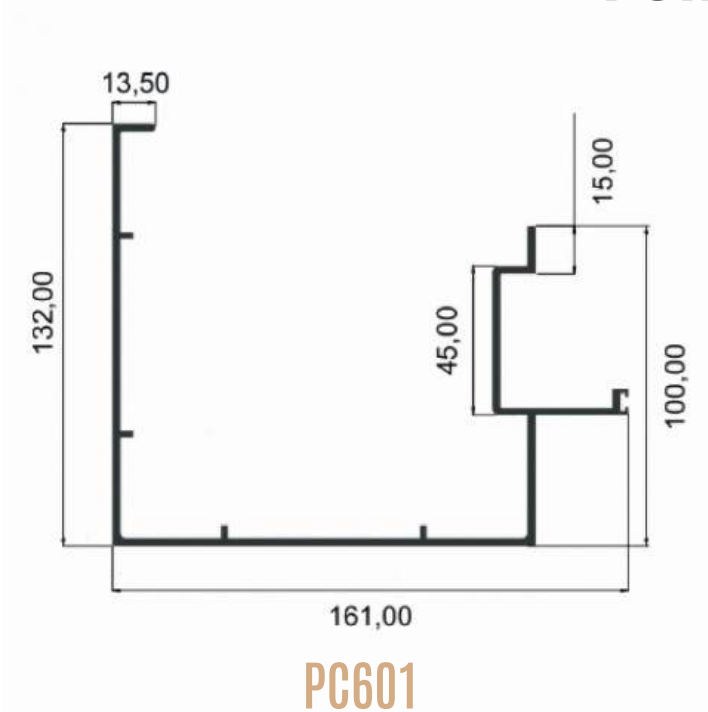

PC601

16,20 Kg - C/ 6 MT
13,50 Kg - C/ 5 MT

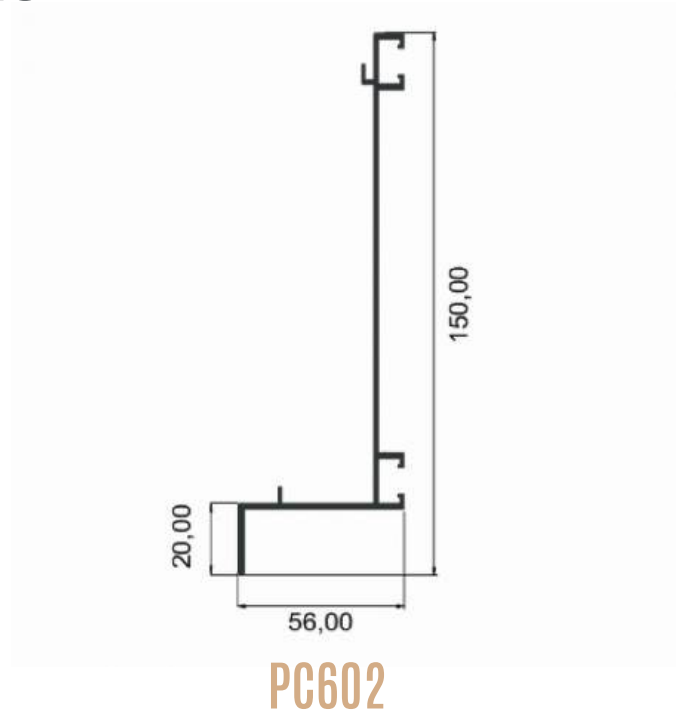

PC602

7,20 Kg - C/ 6 MT
6,00 Kg - C/ 5 MT

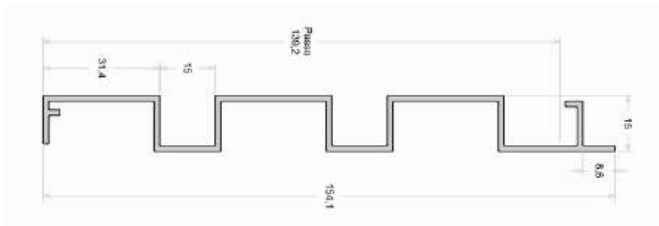

LB064

5,3 Kg | BR

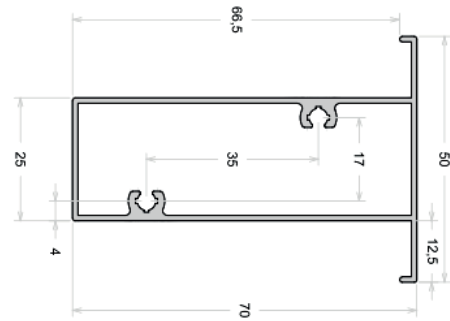

FC070

4,7 Kg | BR

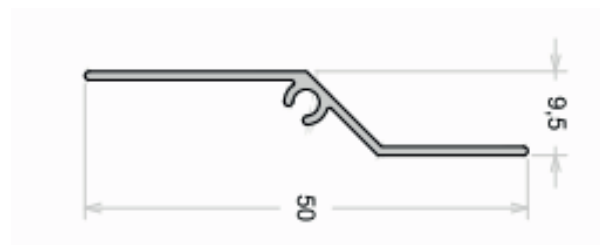

VZ025

1,15 Kg | BR

LINHA SUPREMA

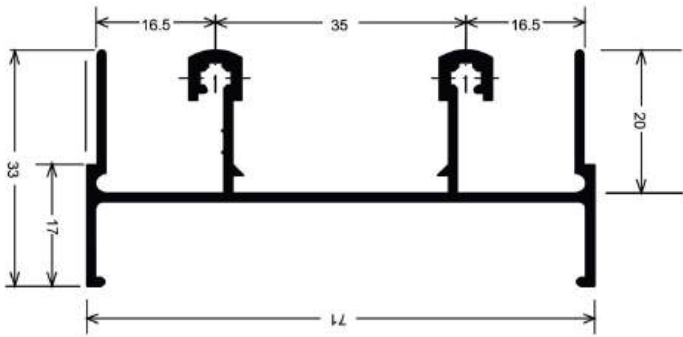

SU001
4,5 Kg

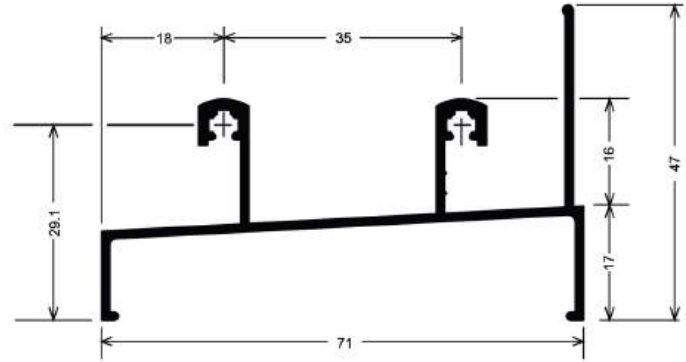

SU002
4,17 Kg

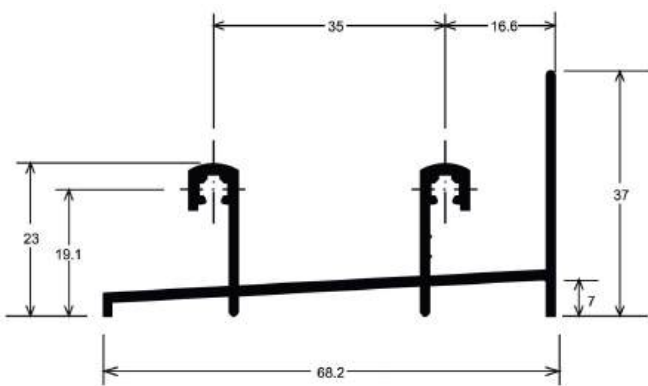

SU228
4,33 Kg

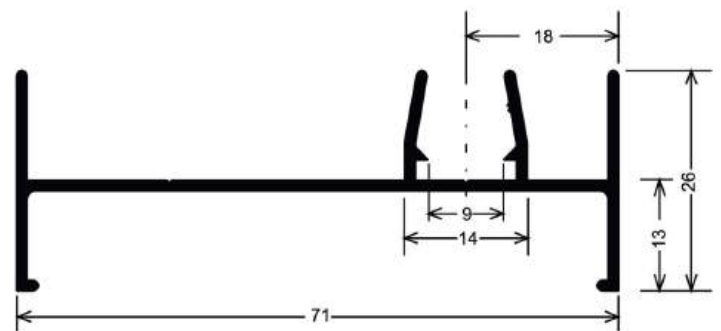

SU003
3,12 Kg

LINHA SUPREMA

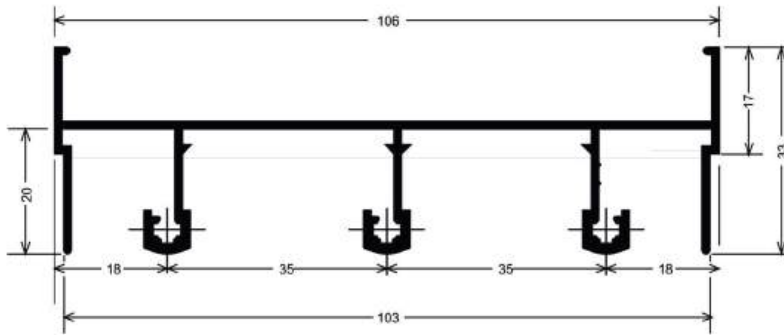

SU010
6,3 Kg

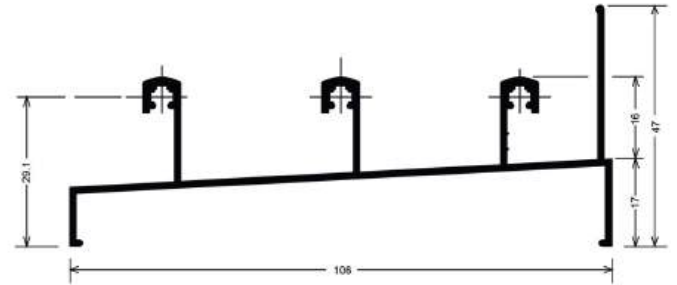

SU011
6,1 Kg

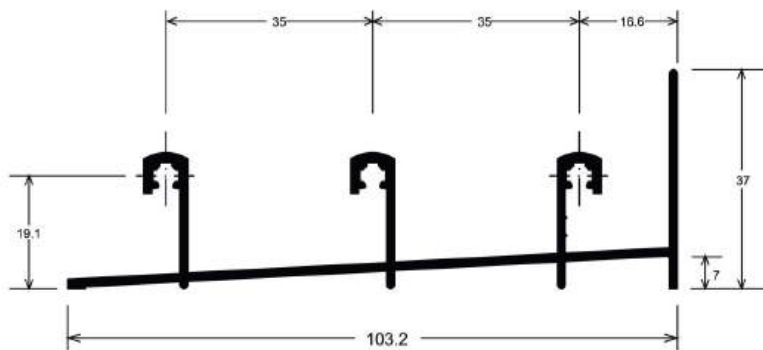

SU230
5,4 Kg

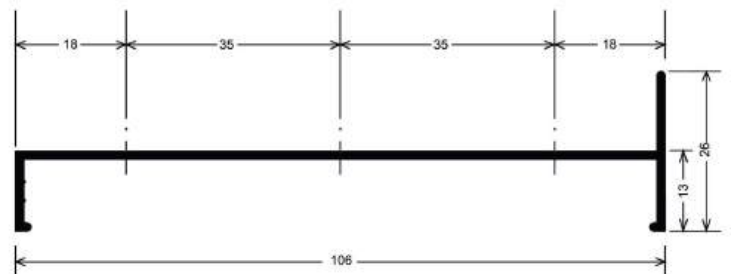

SU012
3,24 Kg

LINHA SUPREMA

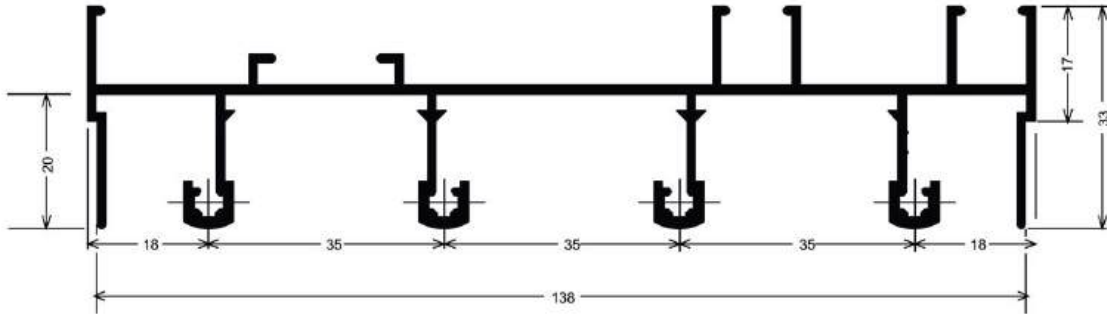

SU121
9,9 Kg

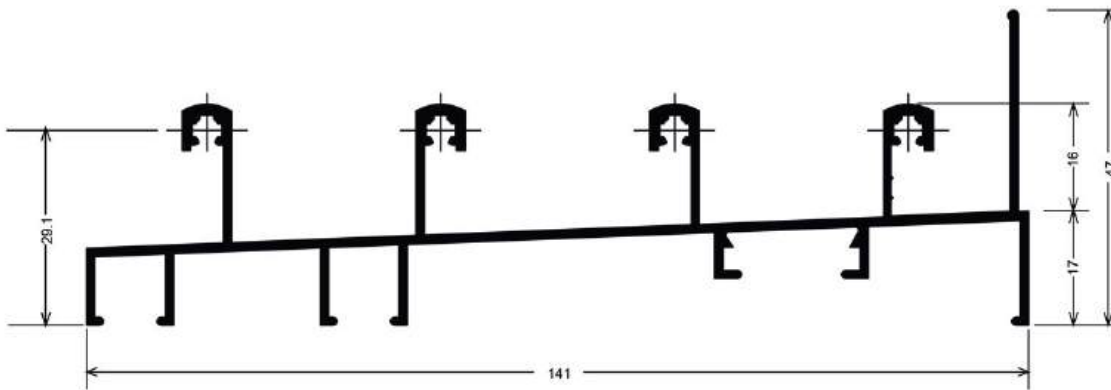

SU122
9,2 Kg

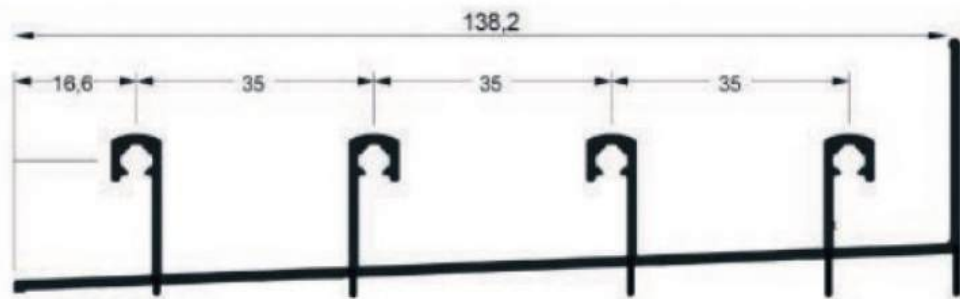

SU124
7 Kg

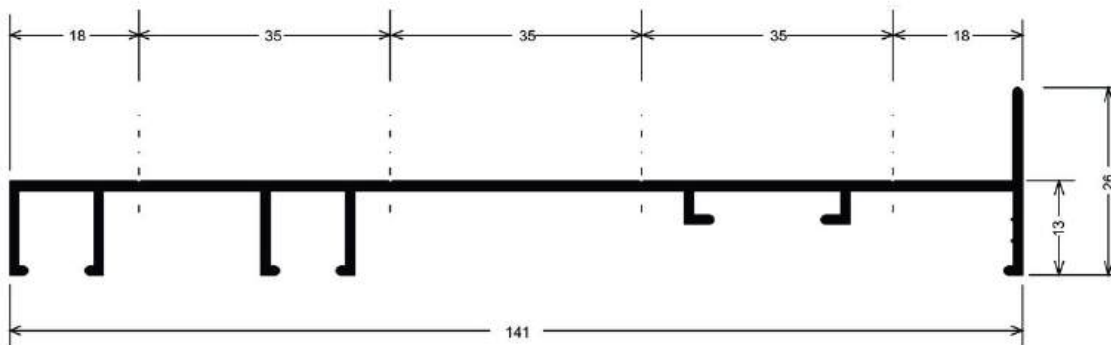

SU123
5,6 Kg

LINHA SUPREMA

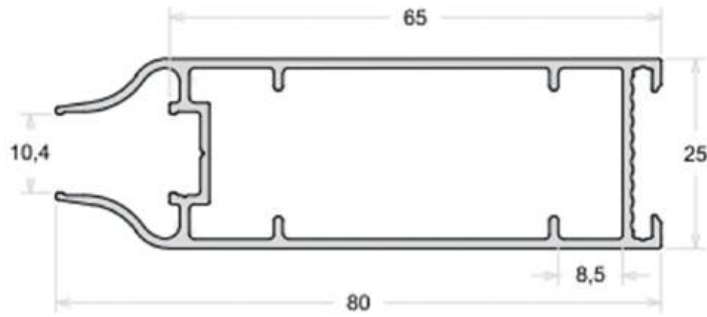

SU350
4,7 Kg

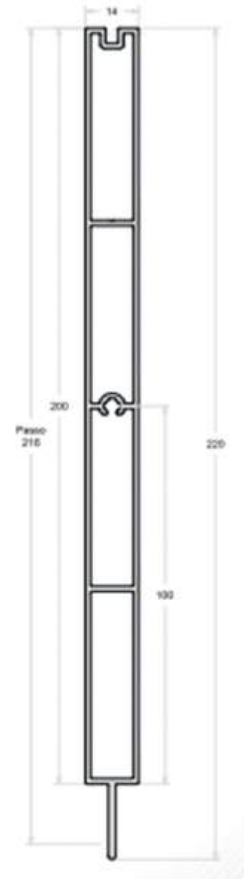

LB030
11,4 Kg

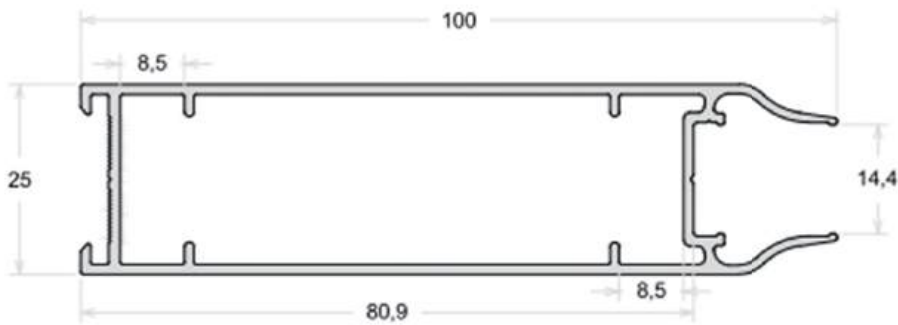

SU450
5,8 Kg

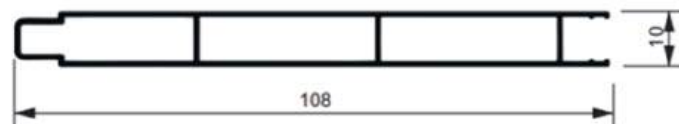

LB061
3,45 Kg

LINHA SUPREMA

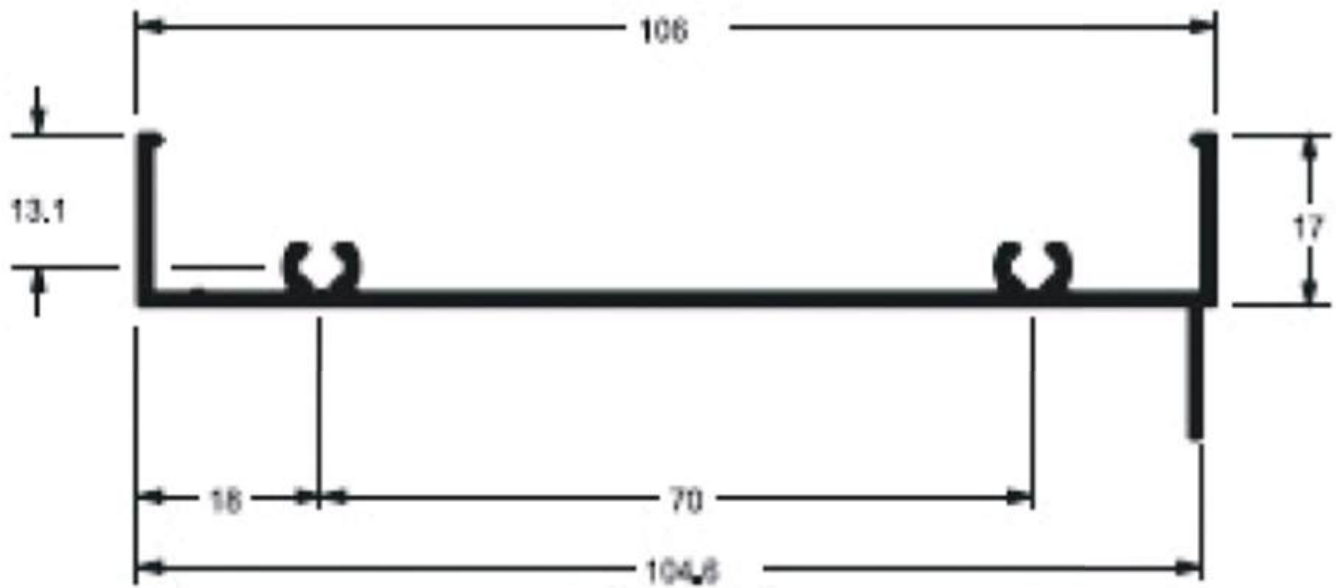

SU018
4,0 Kg

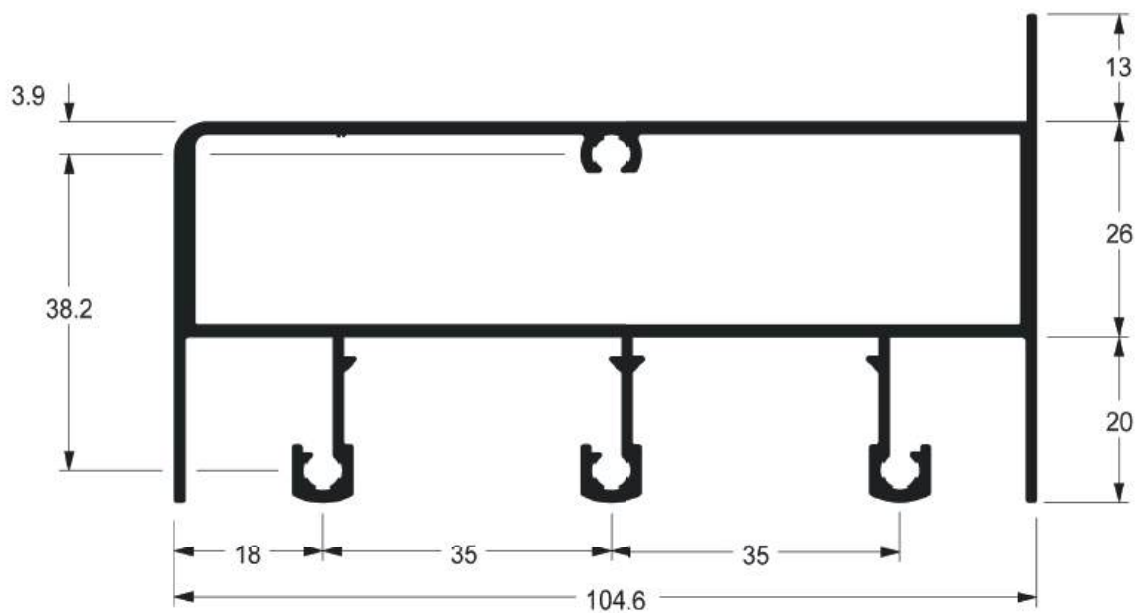

SU019
10,90 Kg

LINHA SUPREMA

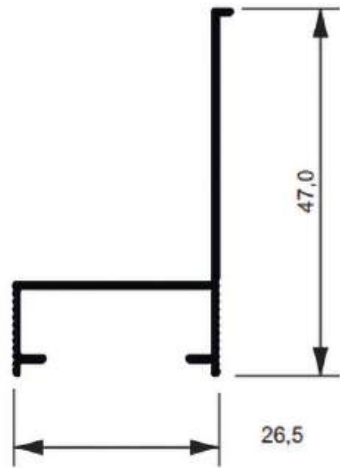

CM151
1,5 Kg

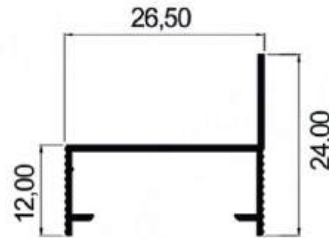

CM063
1,0 Kg

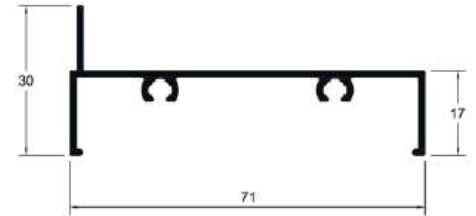

SU004
3,05 Kg

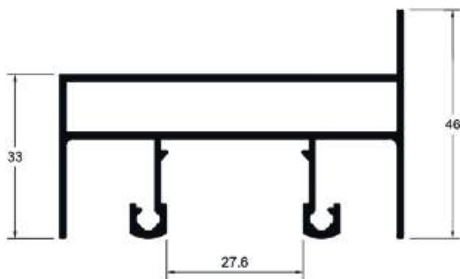

SU005
6,7 Kg

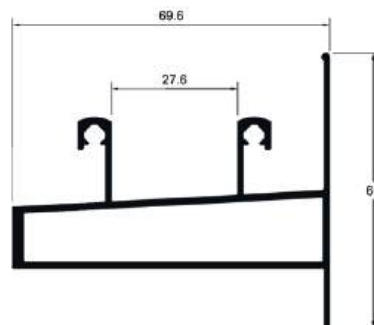

SU006
6,5 Kg

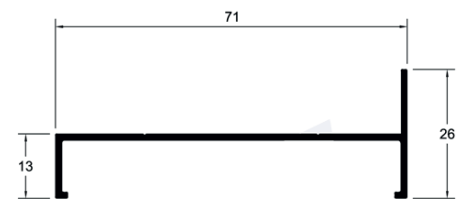

SU007
2,3 Kg

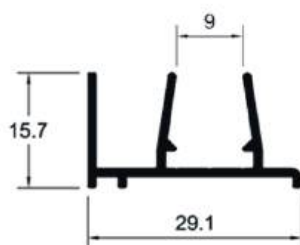

SU008
1,2 Kg

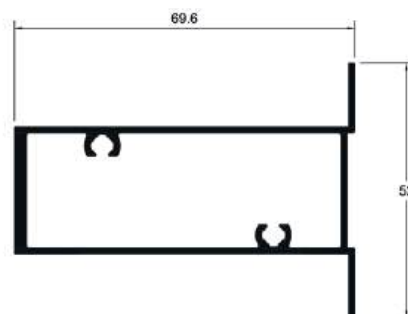

SU009
4,7 Kg

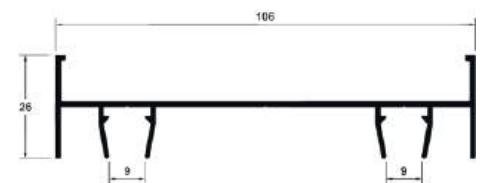

SU013
4,9 Kg

LINHA SUPREMA

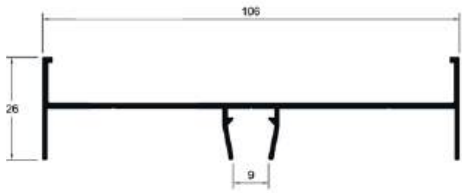

SU014
4,25 Kg

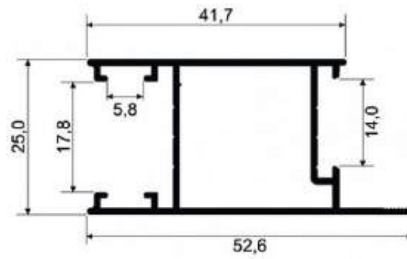

SU039
3,2 Kg

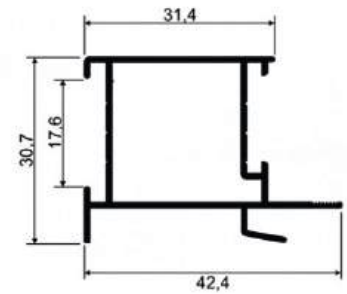

SU040
3 Kg

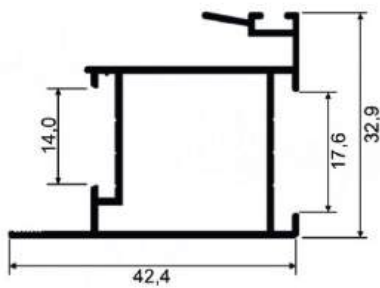

SU041
3,1 Kg

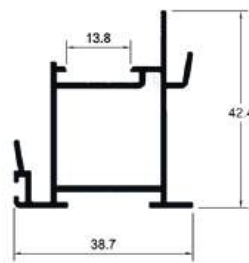

SU042
3,4 Kg

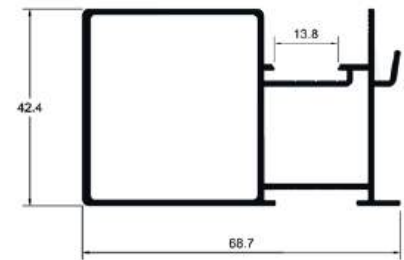

SU047
4,7 Kg
PERFIL C/ 4,60

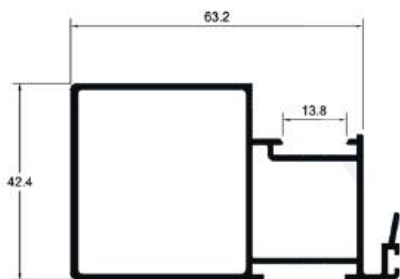

SU049
4,7 Kg
PERFIL C/ 4,60

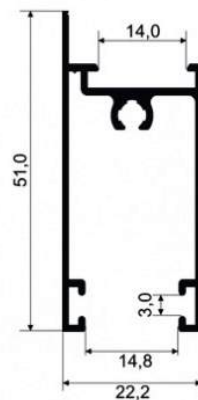

SU053
3,05 Kg

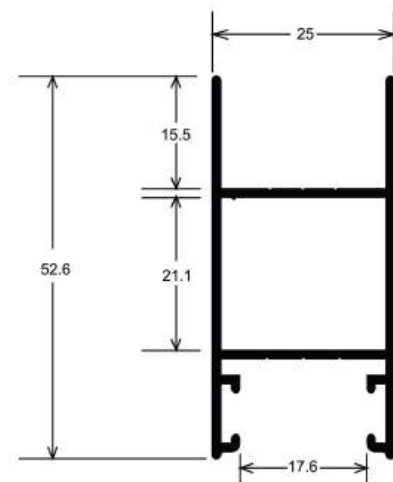

SU068
3,3 Kg

LINHA SUPREMA

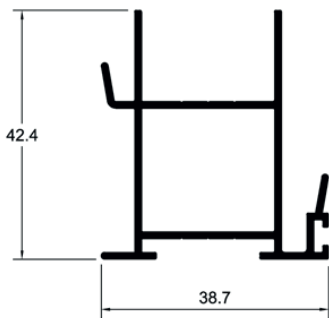

SU069
3,5 Kg

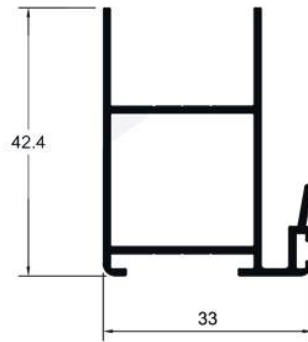

SU070
3,2 Kg

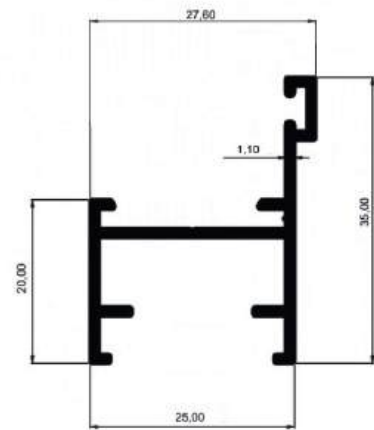

SU079
2,1 Kg

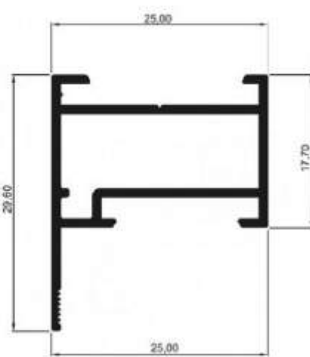

SU080
2,2 Kg

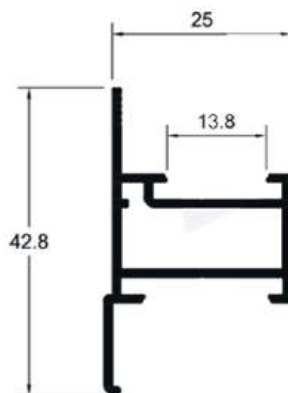

SU081
2,5 Kg

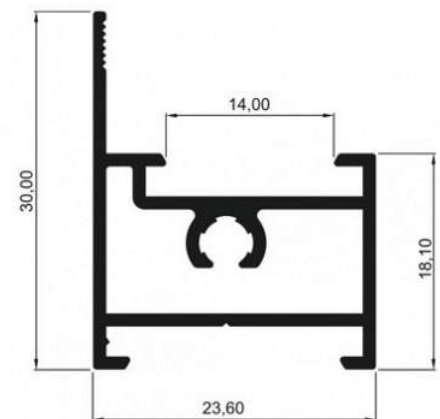

SU082
2,3 Kg

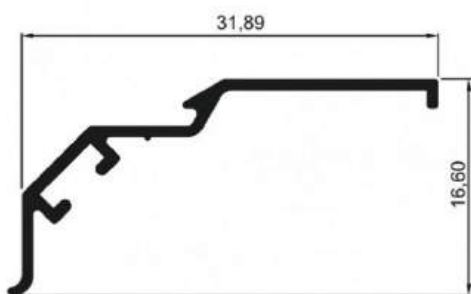

SU083
0,9 Kg

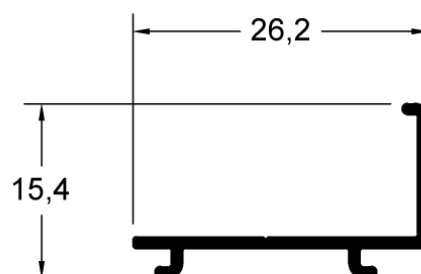

SU084
0,82 Kg

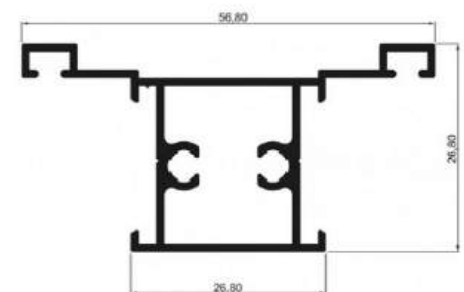

SU086
3,62 Kg

LINHA SUPREMA

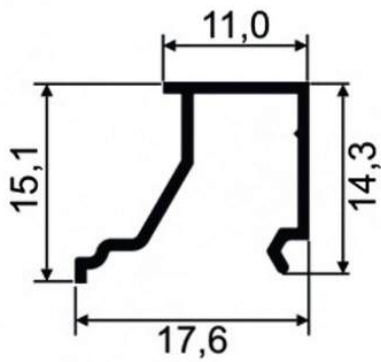

SU102
0,7 Kg

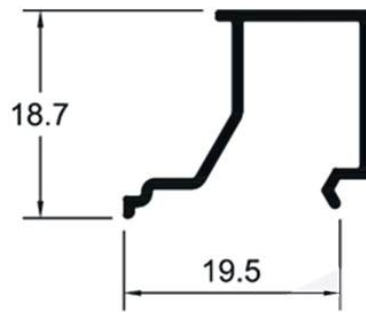

SU103
0,85 Kg

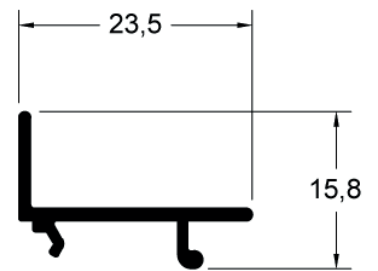

SU108
0,9 Kg

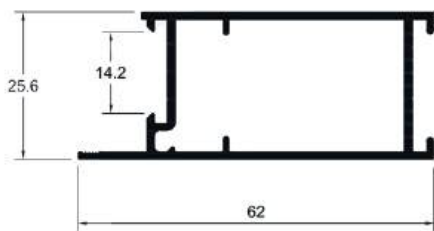

SU111
4 Kg

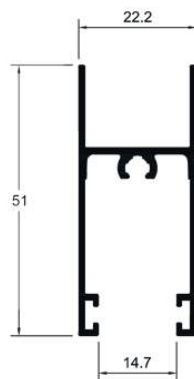

SU187
3,2 Kg

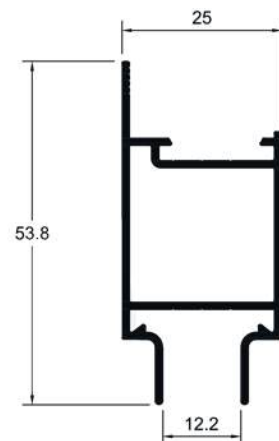

SU192
3,35 Kg



SU225
5,93 Kg

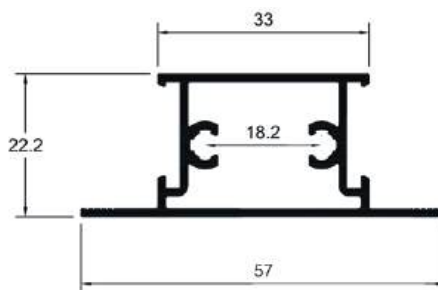

SU227
3,43 Kg

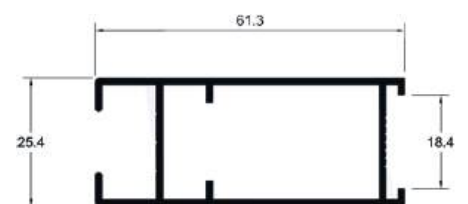

SU241
4,4 Kg

LINHA SUPREMA

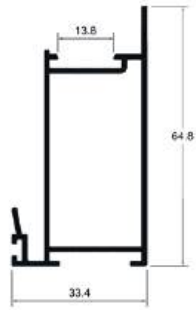

SU242
4,1 Kg

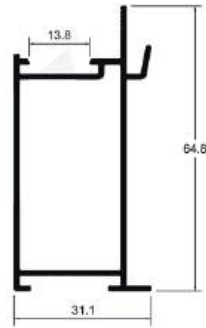

SU243
3,85 Kg

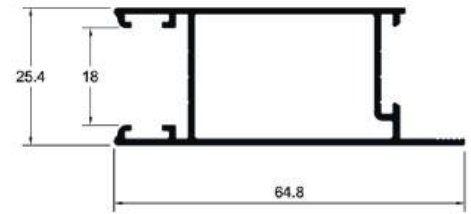

SU245
3,78 Kg

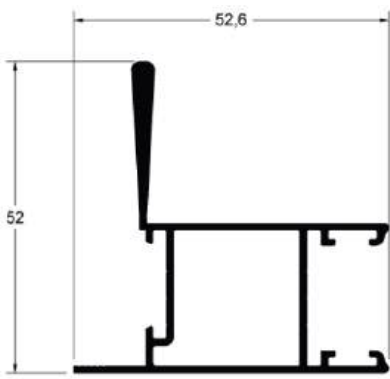

SU250
3,5 Kg
PERFIL C/ 4,60

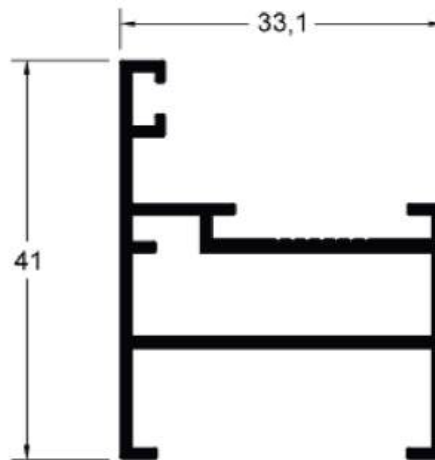

SU279
3,35 Kg

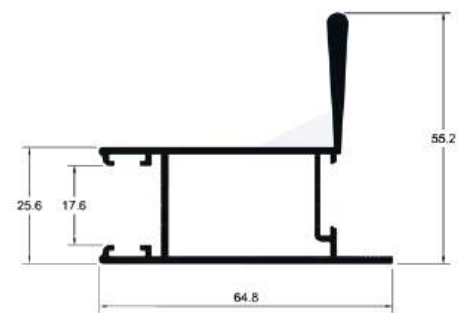

SU280
4,7 Kg
PERFIL C/ 4,60

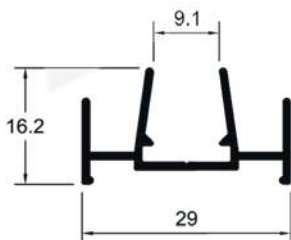

SU291
1,45 Kg

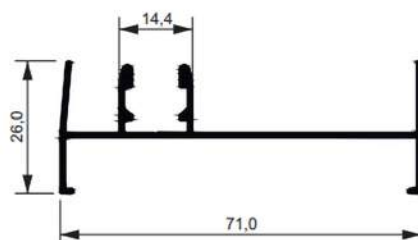

SU303
2,9 Kg

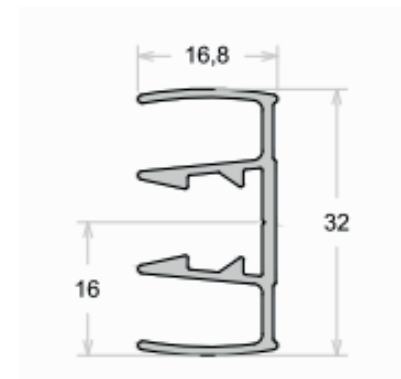

SU334
2,3 Kg

LINHA SUPREMA

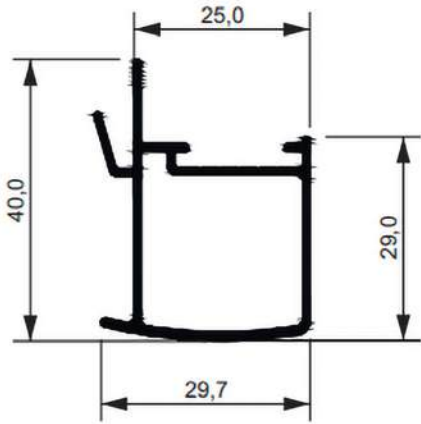

SU340
2,75 Kg

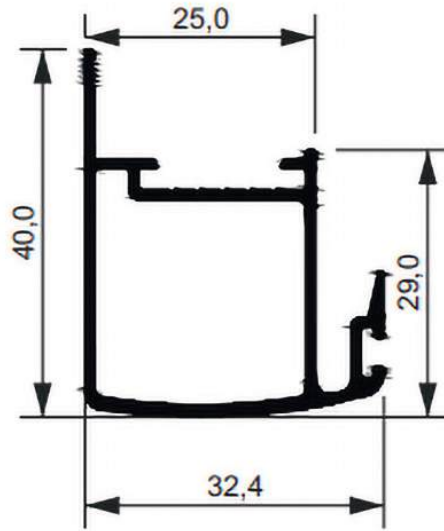

SU341
3 Kg

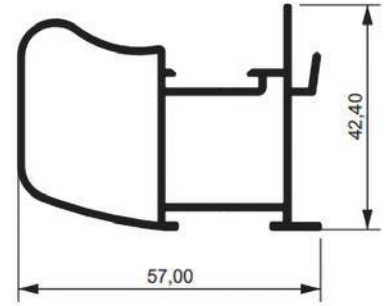

SU347
3,5 Kg
PERFIL C/ 4,60

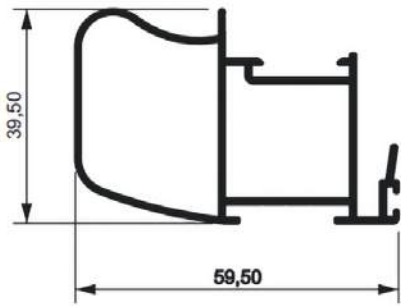

SU349
3,5 Kg
PERFIL C/ 4,60

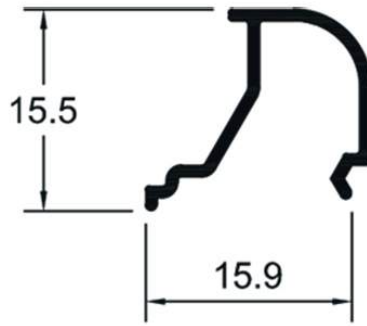

SU500
0,68 Kg

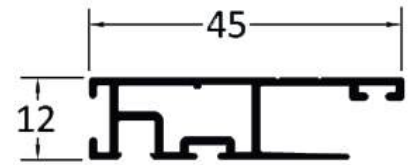

SU551
1,9 Kg

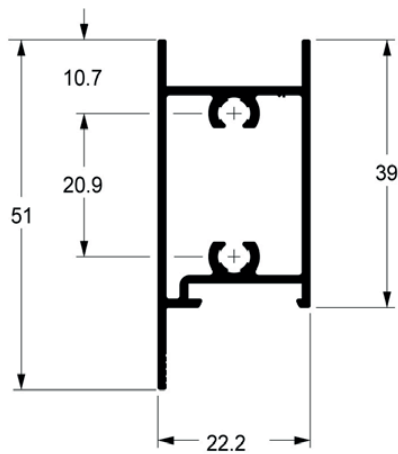

SU110
1,8 Kg

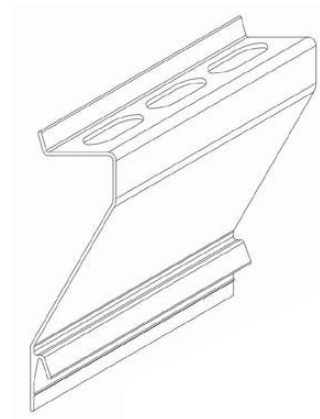

US285
1,85 Kg

LINHA SUPREMA

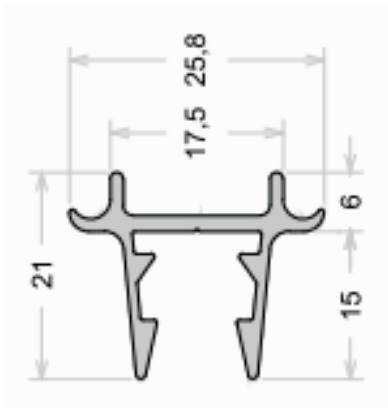

SU305
1,62 Kg

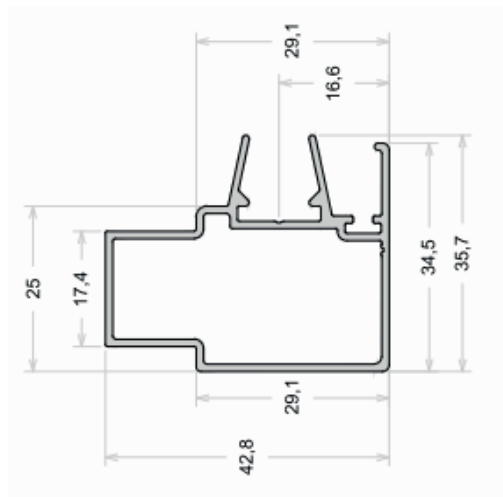

SU038
3,3 Kg

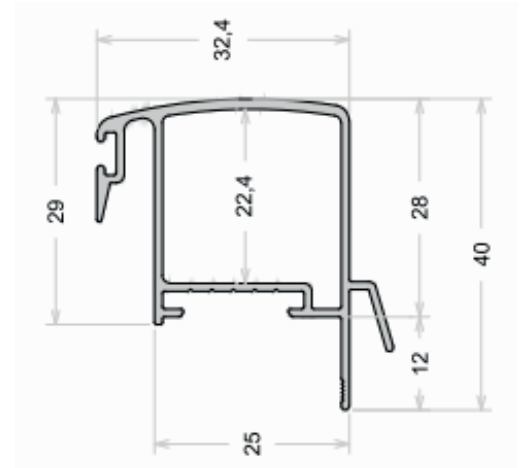

SU342
2,8 Kg

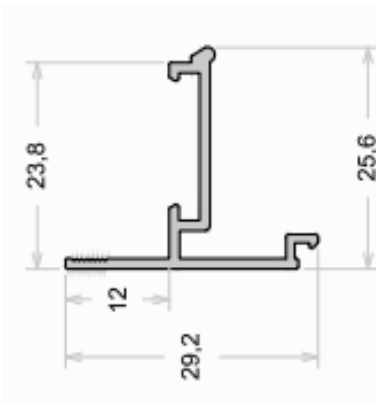

SU292
1,35 Kg

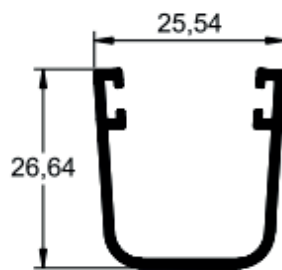

SU107
1,7 Kg | BR

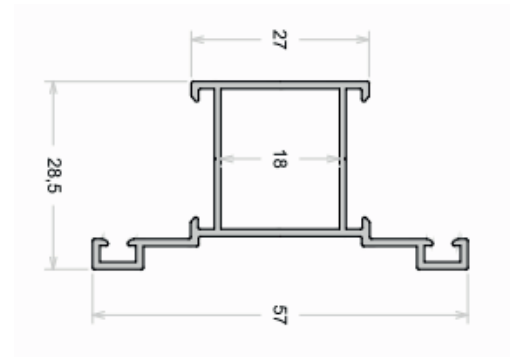

SU085
3,2 Kg | BR



VZP / VZC

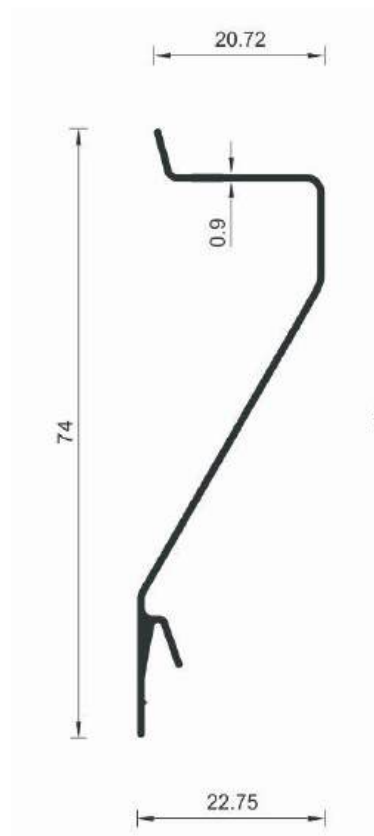
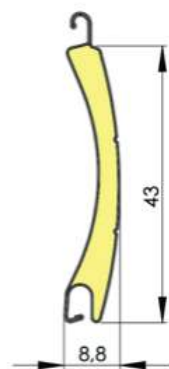

VZ006
1,8 Kg

LINHA SUPREMA

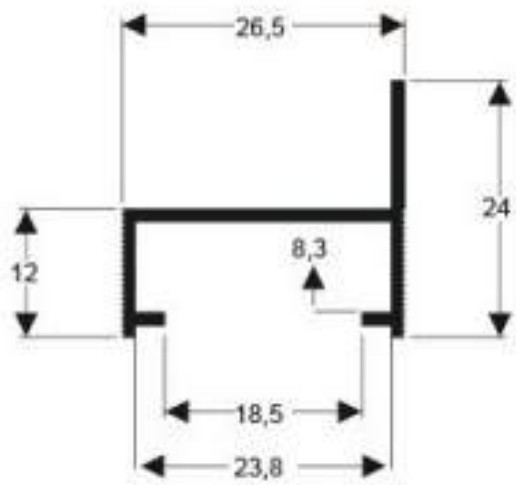

CM063
0,93 Kg

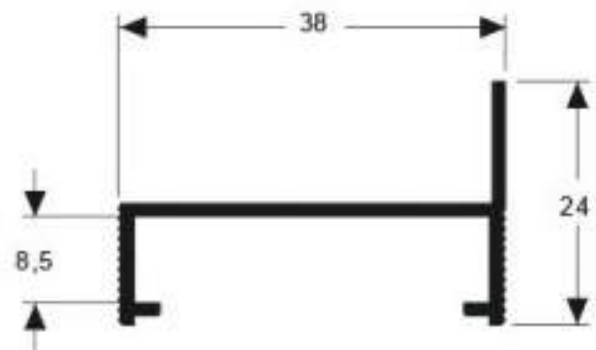

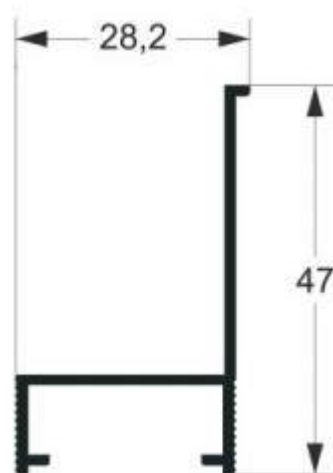

CM060
1,32 Kg



CM151
1,464 Kg

LINHA SUPREMA

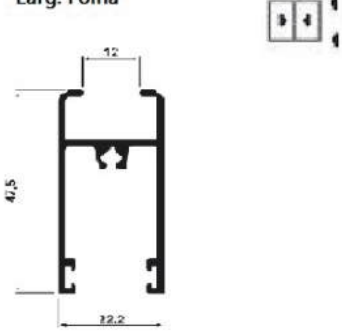
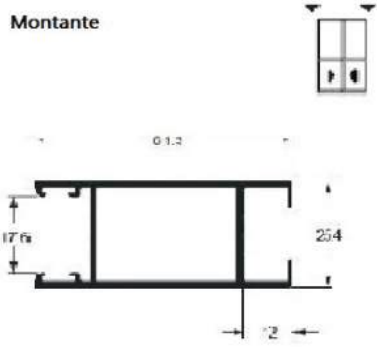
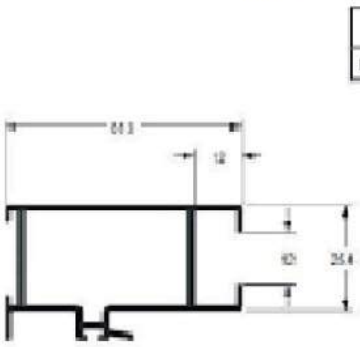
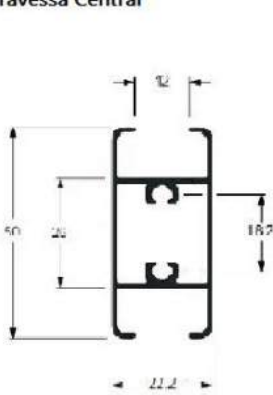
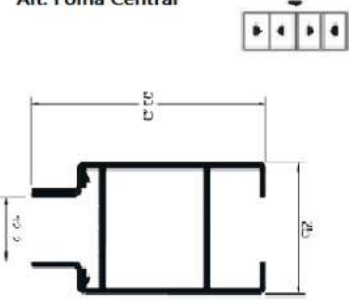
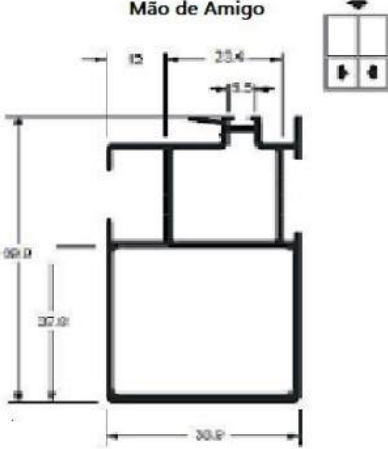
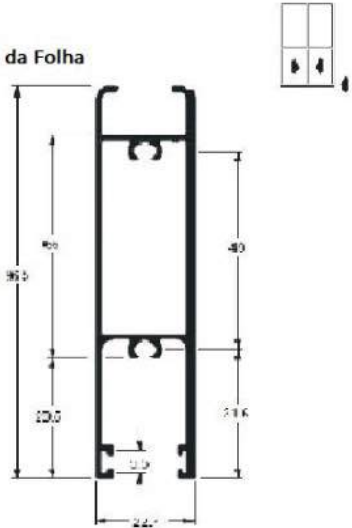
<p>Montante</p>  <p>SU-055 3,30 Kg</p>	<p>Mão de Amigo</p>  <p>SU-056 3,10 Kg</p>	<p>Larg. Folha</p>  <p>SU-186 3,20 Kg</p>
<p>Montante</p>  <p>SU-238 4,30 Kg c/ 6000mm</p>	<p>Mão de Amigo</p>  <p>SU-239 4,70 Kg c/ 6000mm</p>	<p>Travessa Central</p>  <p>SU-188 3,50 Kg</p>
<p>Alt. Folha Central</p>  <p>SU-190 3,30 Kg</p>	<p>Mão de Amigo</p>  <p>SU-061 6,40 Kg c/ 6000mm 4,90 Kg c/ 4600mm</p>	<p>Larg. Inf. da Folha</p>  <p>SU-226 6,10 Kg</p>

LINHA SUPREMA

Montante Lat. e Inf. da Folha 45/45°



SU-090
2,70 Kg

Montante Sup. da Folha 45/45°

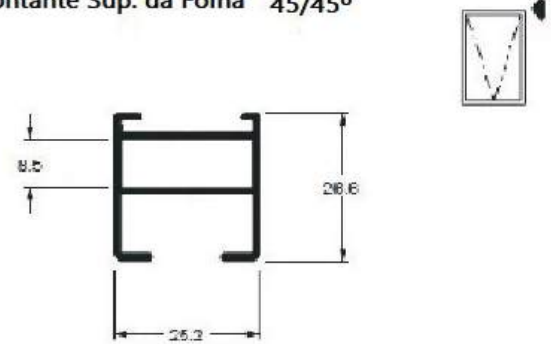

SU-091
2,40 Kg

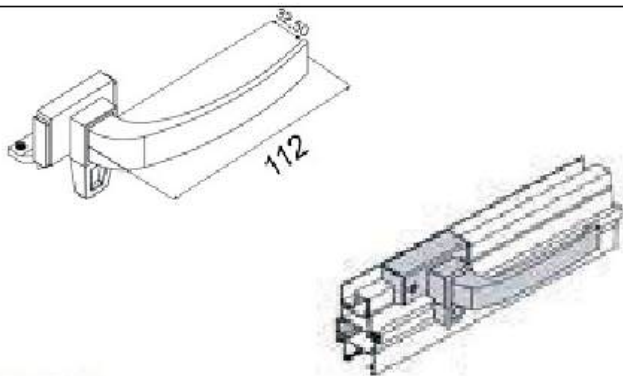

FEC-010
Fecho Direito p/ Maxi-ar s/ Baguete

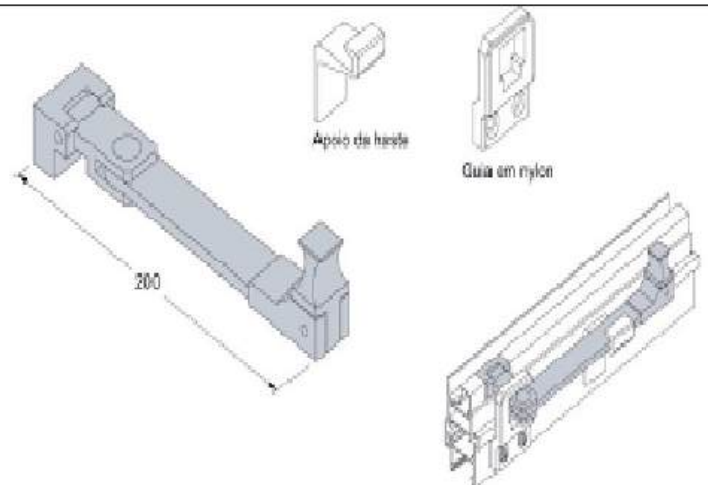

FEC-011
Haste de Comando p/ Maxi-ar s/ Baguete

LINHA SUPREMA

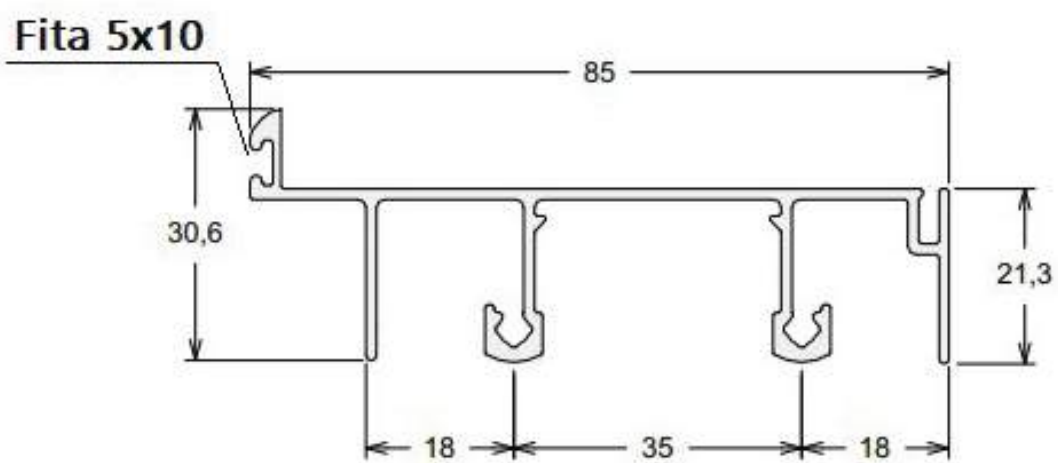
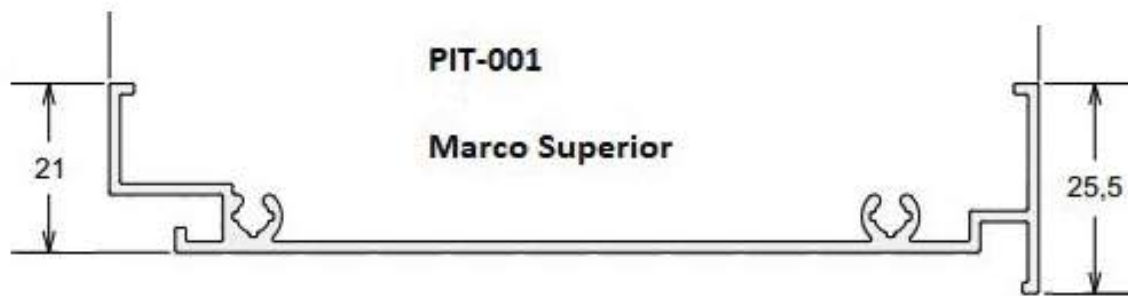

PIT-002

Marco Intermediário

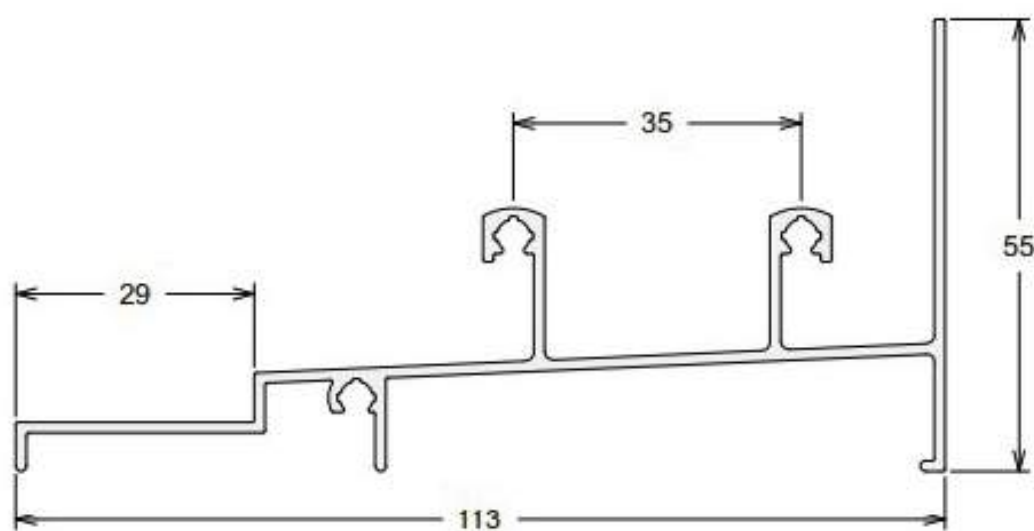

PIT-003

Marco Inferior

LINHA SUPREMA

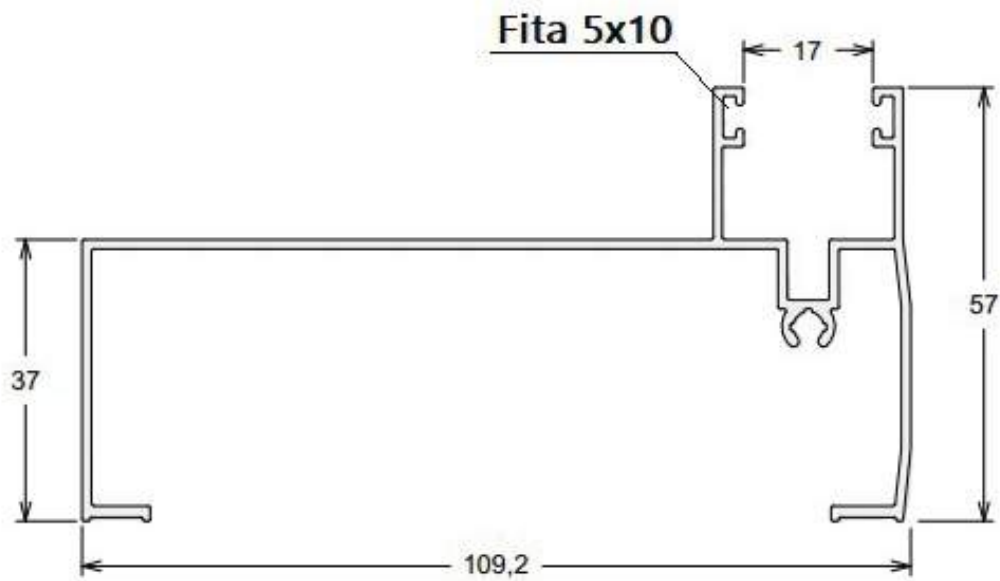

PIT-004

Caixa do Recolhedor Manual

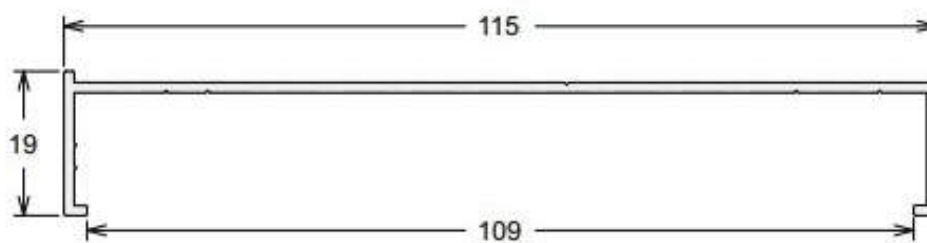

PIT-010

Marco Lateral

LINHA SUPREMA

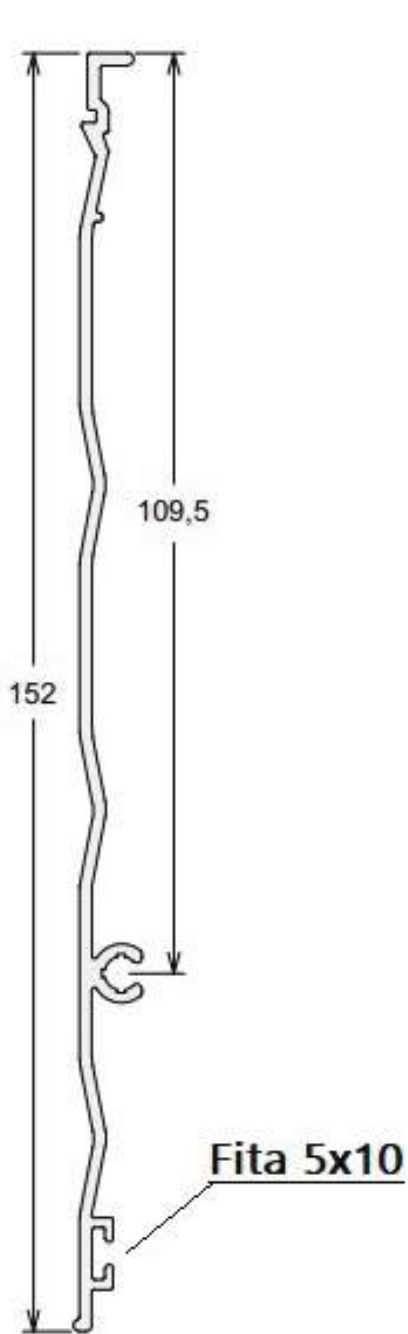

PIT-007

Tapa Externa Pequena

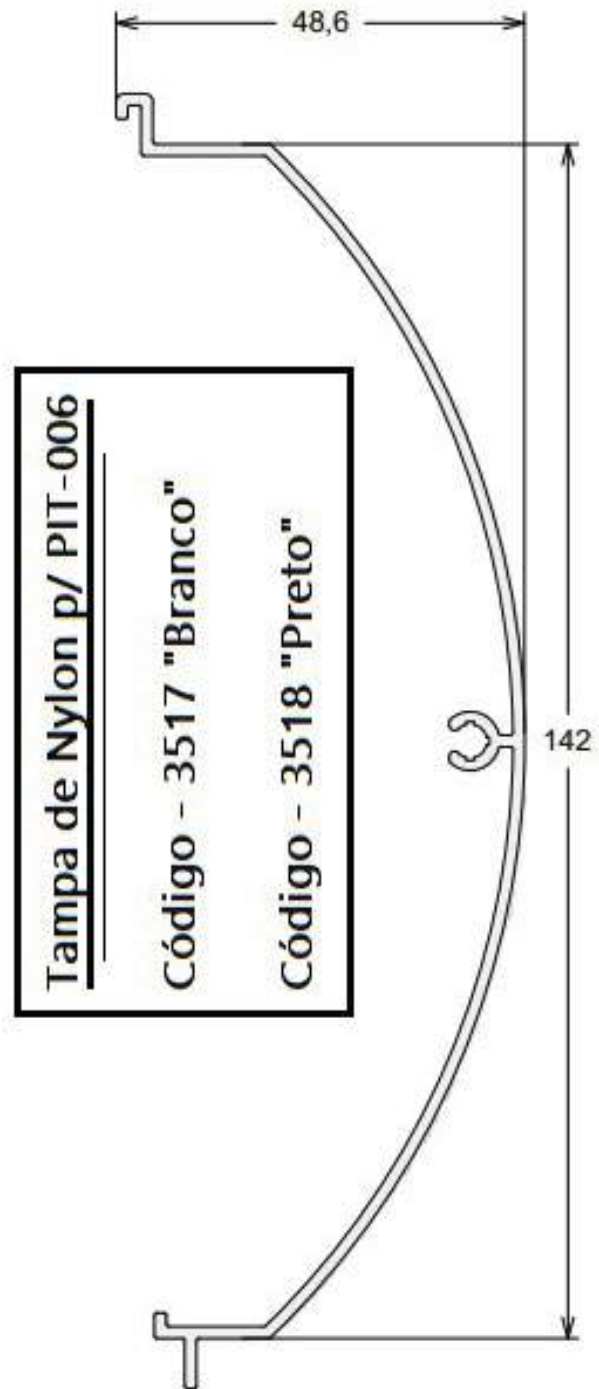

PIT-006

Tapa Interna Pequena

LINHA SUPREMA

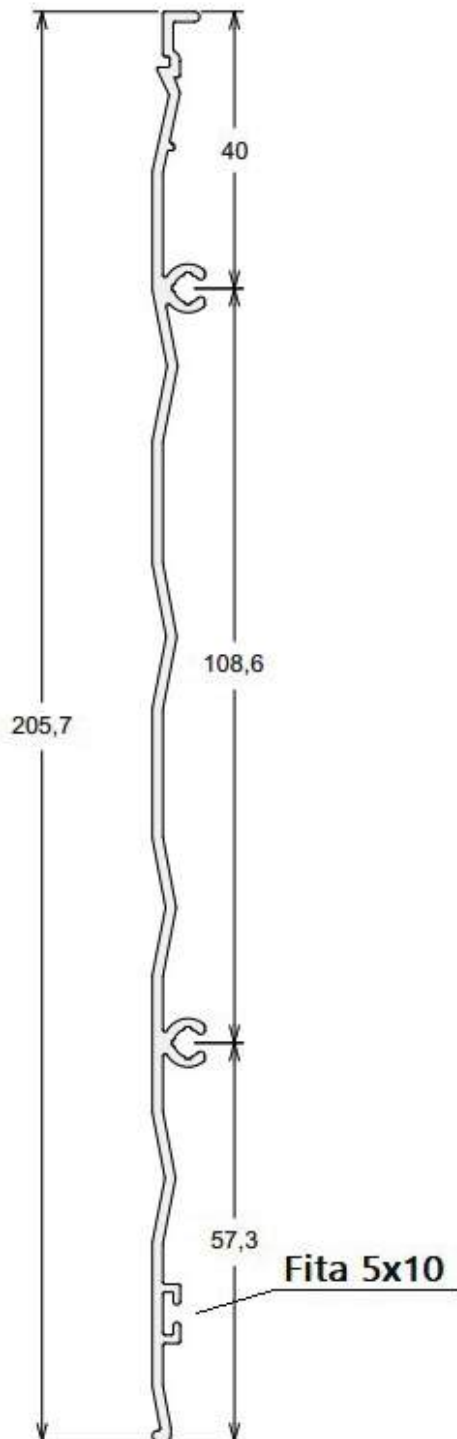

PIT-015

Tapa Externa Grande

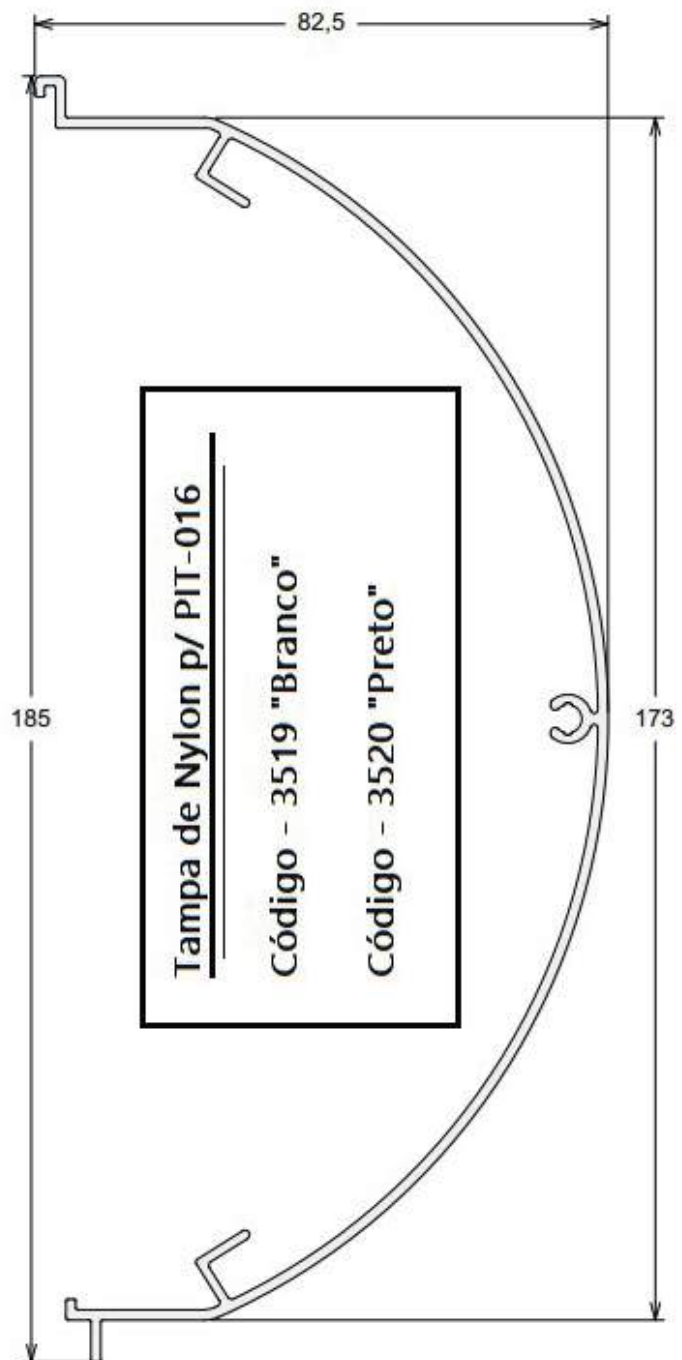

PIT-016

Tapa Externa Grande

LINHA SUPREMA

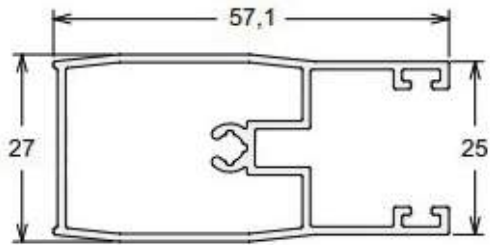

PIT-005

Guia da Persiana

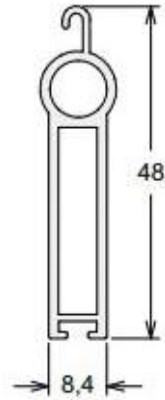

MN-055

Terminal da Persiana

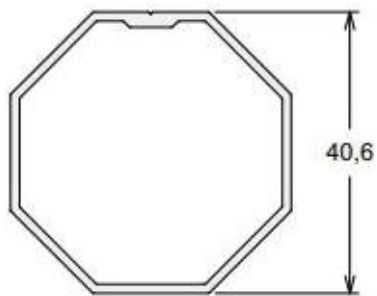

MN-011

Eixo do Recolhedor 40mm

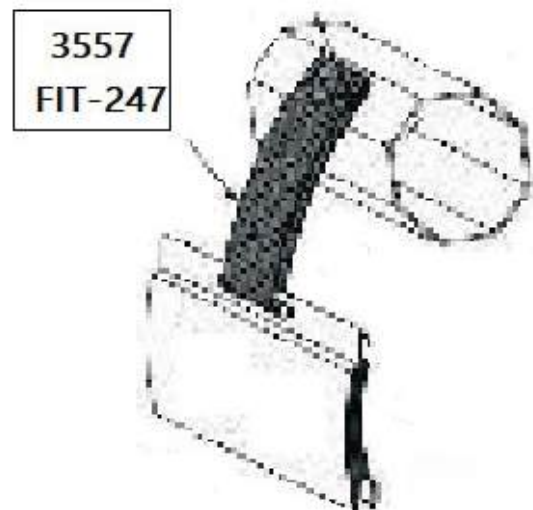

Código 3557 = Fita de Ligação da Persiana

LINHA SUPREMA

Projeto p/ Corte de Janelas Integrada
c/ Automação e Manual

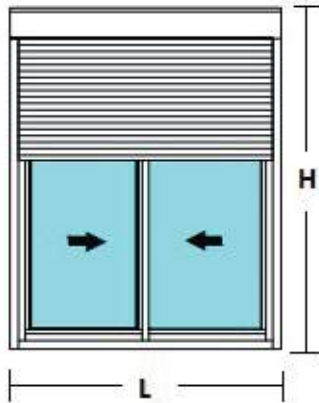

Janela Integrada Automatizada

Larg. Folha = $(L-146)/2$

Altura Folha = $H-203$

Janela Integrada Manual

Larg. Folha = $(L-184)/2$

Altura Folha = $(H-203)$

Bag. Altfolha = $(H-203)-102$

Observações:

Altura Máxima :

PIT-008 - H1: 1250 mm
H : 1420 mm

PIT-011 - H1: 1400 mm
H : 1570 mm

Considerado Palhetas de 45

Bendini Alumínios

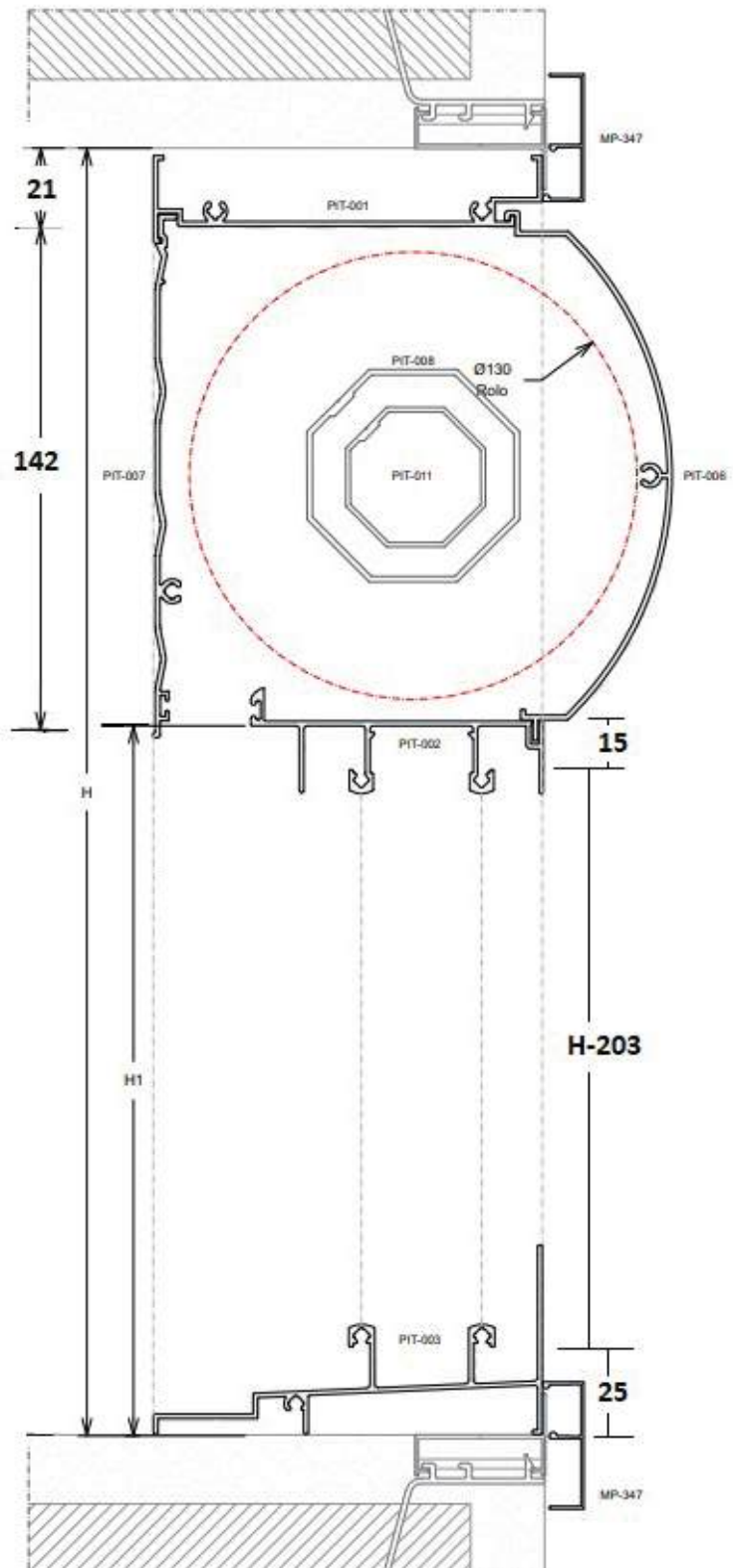

LINHA MP

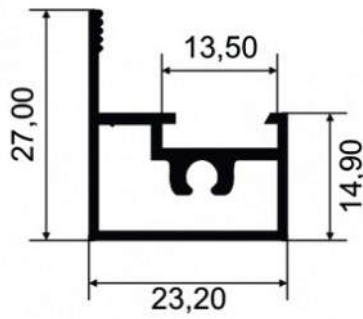

25301
2,08 Kg

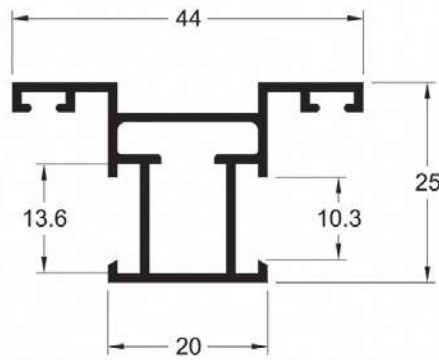

25308
2,7 Kg

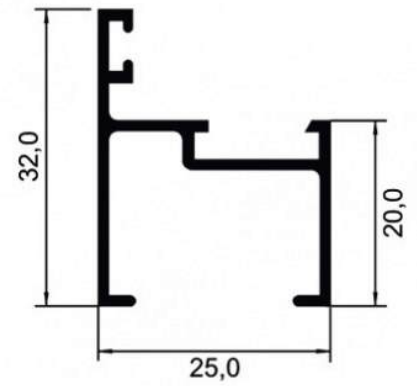

25311
1,8 Kg

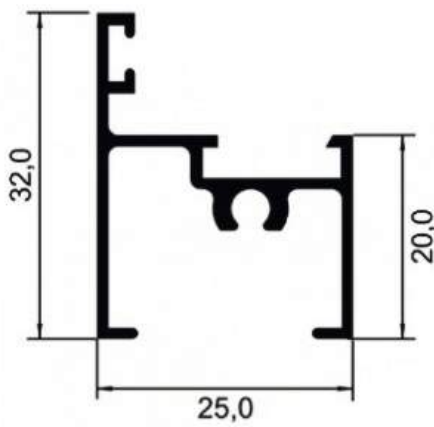

25312
2,1 Kg

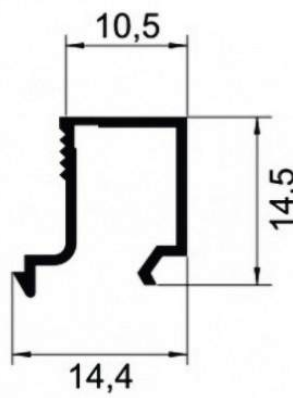

BG035
0,76 Kg

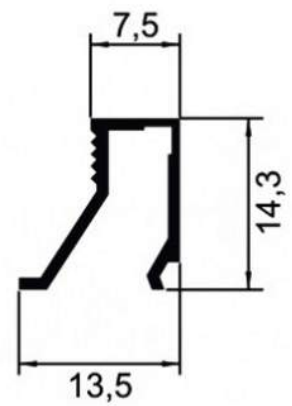

BG202
0,7 Kg

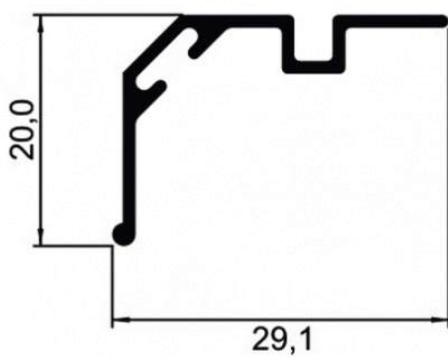

ME056
1,26 Kg

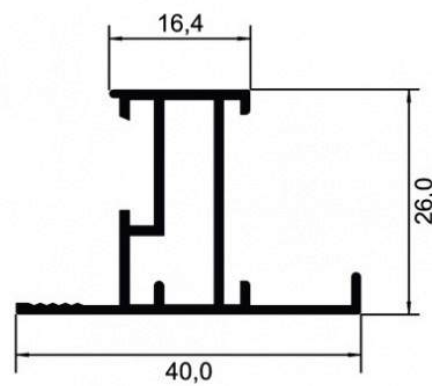

MM375
2,65 Kg

LINHA MP

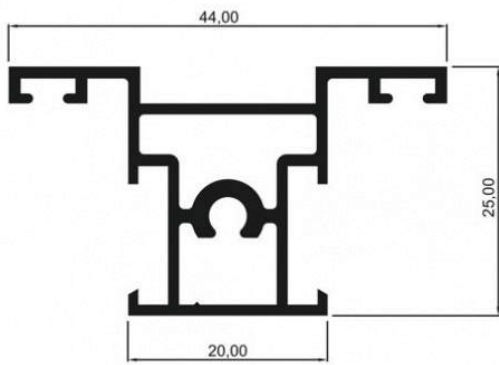

MM376
3,4 Kg

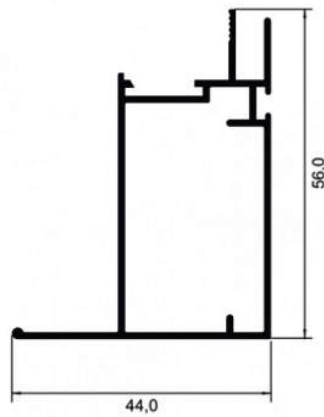

MP069
3,6 Kg
PERFIL C/ 4,6

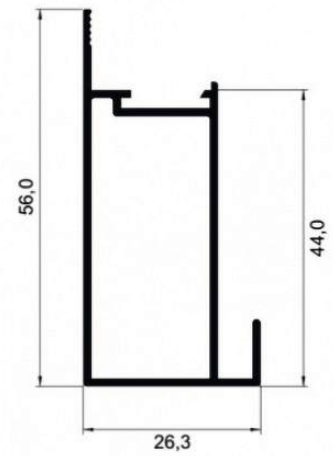

MP070
3 Kg
PERFIL C/ 4,6

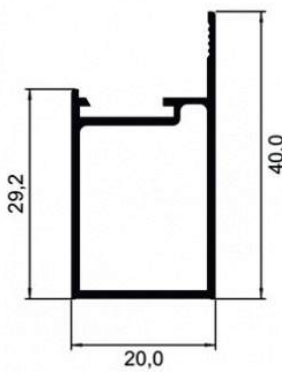

MP300
2,05 Kg

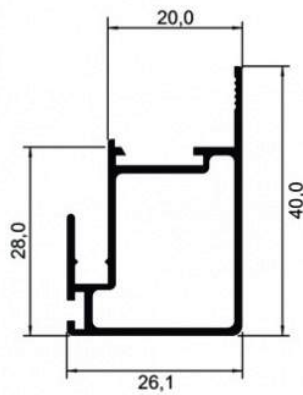

MP302
2,45 Kg

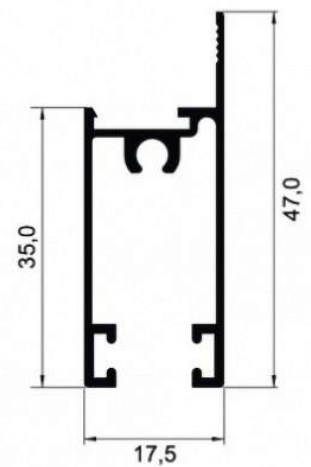

MP309
2,6 Kg

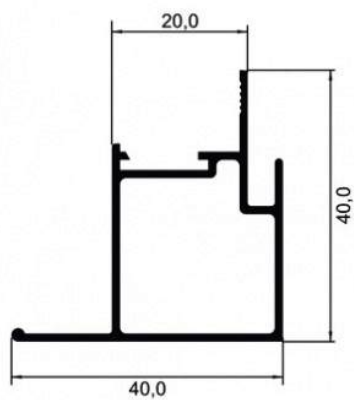

MP321
2,64 Kg

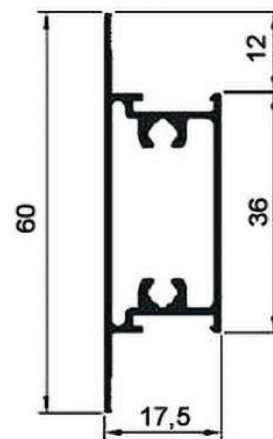

MP332
4 Kg

LINHA MP

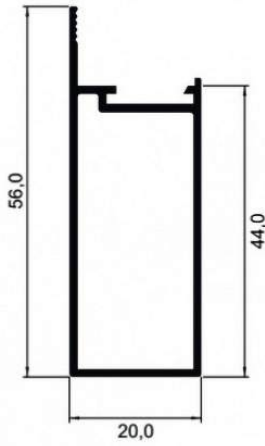

MP336
2,54 Kg

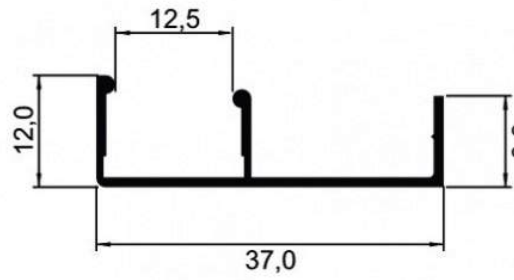

MP347
1,2 Kg

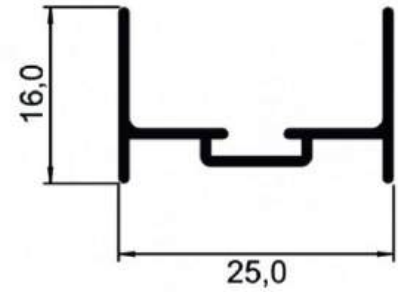

MP352
1,32 Kg

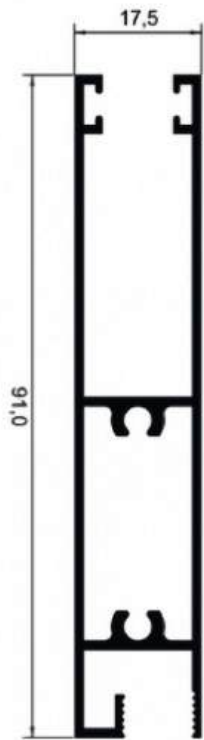

MP354
6,5 Kg

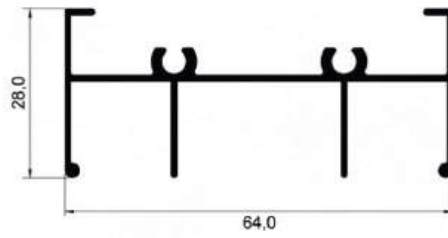

MP357
3,66 Kg

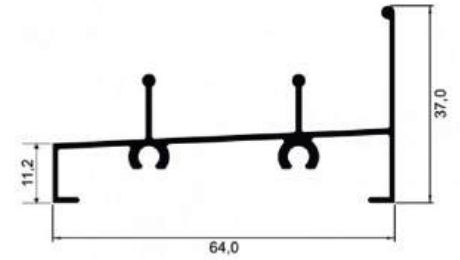

MP358
3,78 Kg

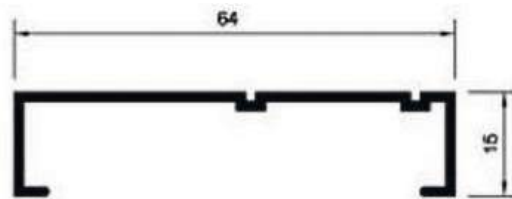

MP359
2,08 Kg

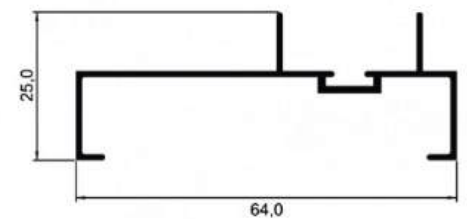

MP360
2,5 Kg

LINHA MP

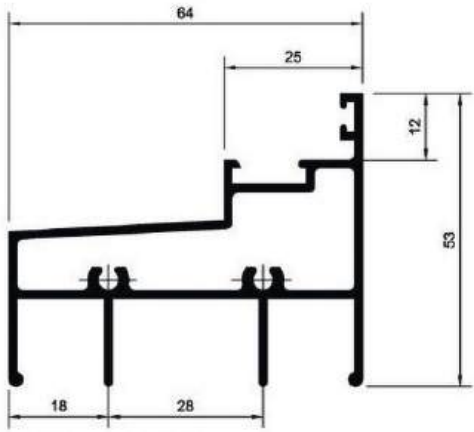

MP361
7,1 Kg
PERFIL C/ 4,6

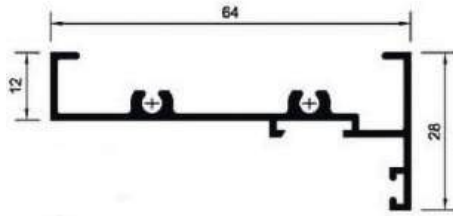

MP363
3,5 Kg

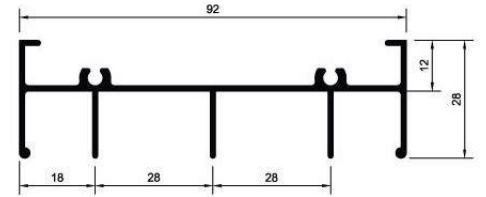

MP366
5,7 Kg

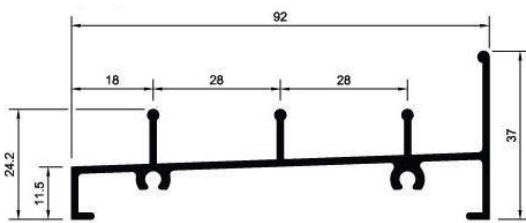

MP367
5,35 Kg

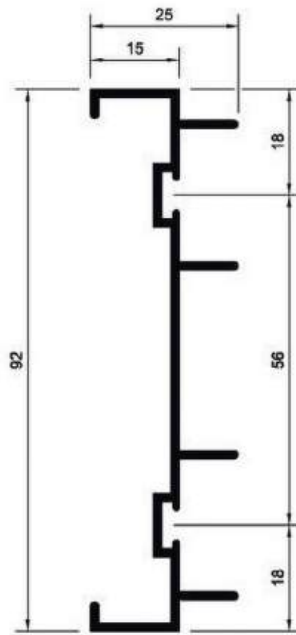

MP368
4,5 Kg

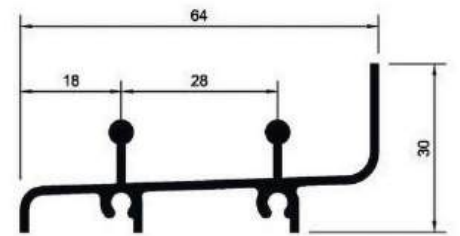

MP370
4,23 Kg

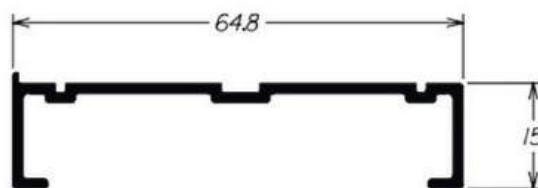

MP397
2,72 Kg

FACHADAS E PERFIS - POLICARBONATO

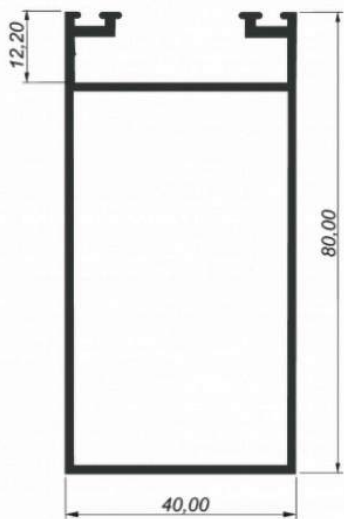

FC012
6,2 Kg

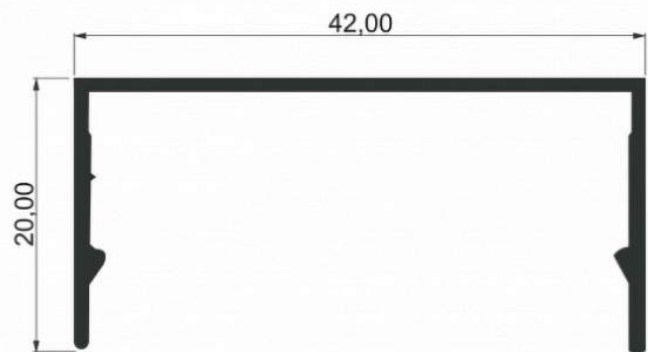

FC013
1,7 Kg

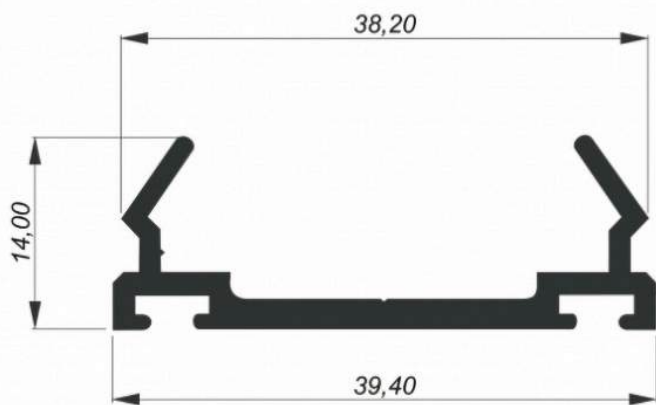

FC014
2 Kg

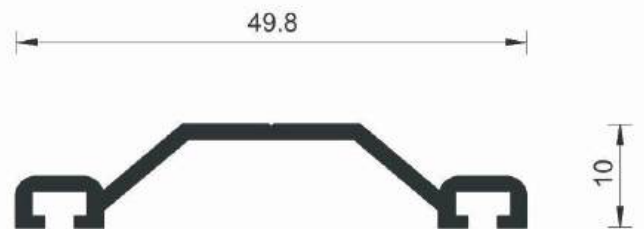

PCA300
2 Kg



PCA301
1,45 Kg

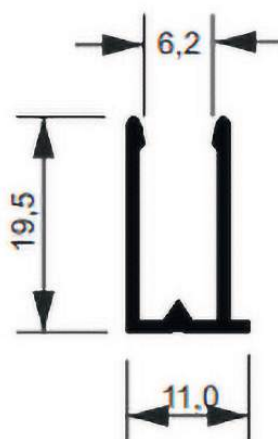

PCB001
1 Kg

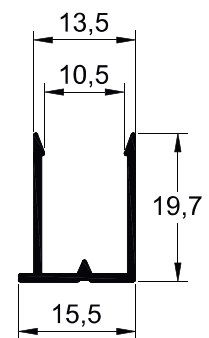

PCB002
1 Kg

LINHA PV2

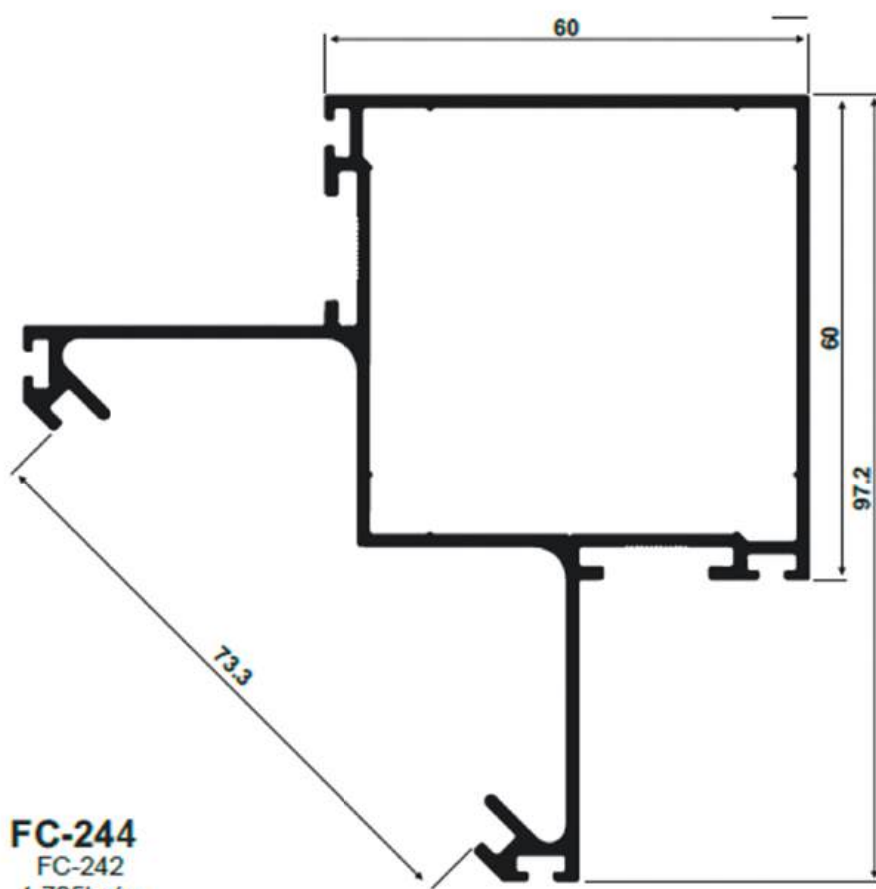

FC-244
FC-242
1,705kg/m

PAT244
10,7 Kg

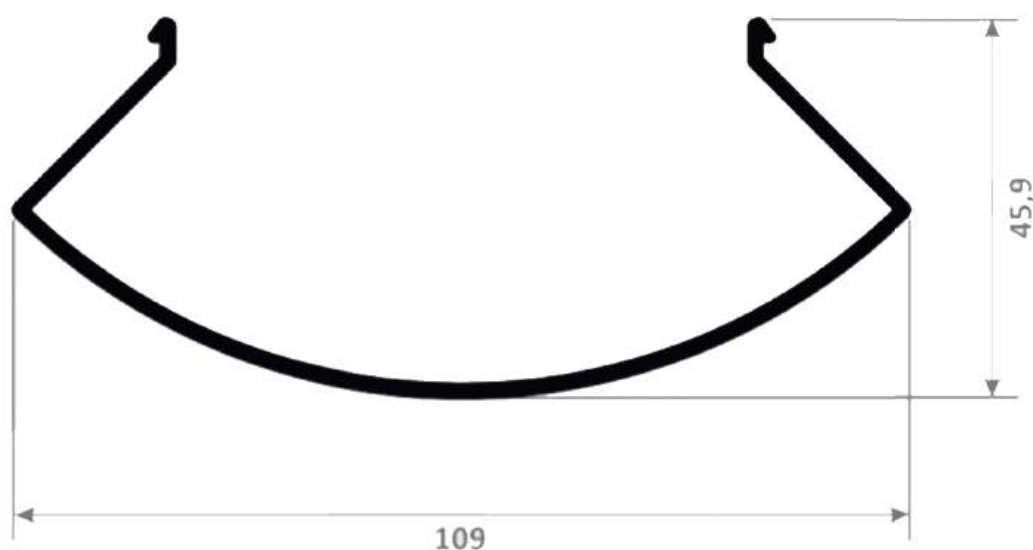

PAT242
4,9 Kg

LINHA PV2

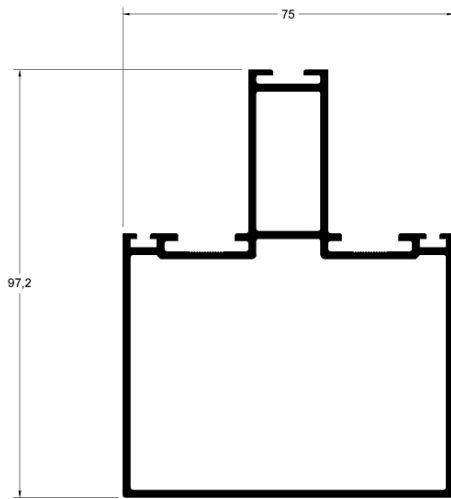

PAT202
 11,8 Kg - C/ 6 MT
 12,8 Kg - C/ 6,5 MT

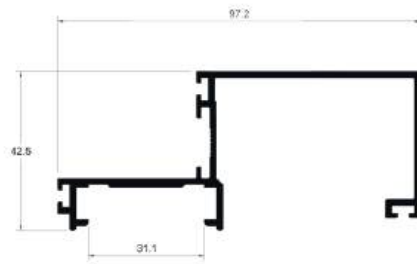

PAT243
 7,5 Kg - C/ 6 MT
 8 Kg - C/ 6,5 MT

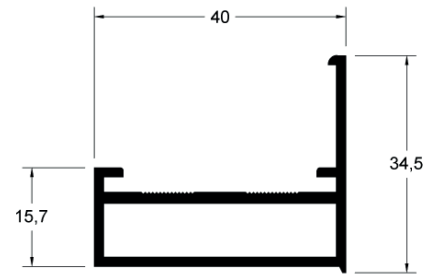

PAT261
 3,67 Kg

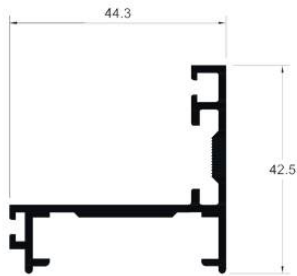

PAT225
 4,2 Kg

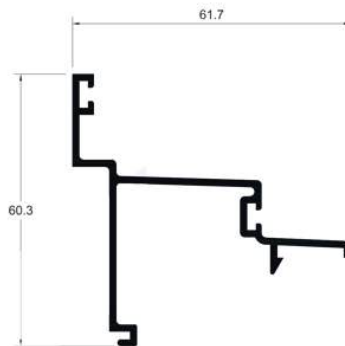

PAT227
 4,45 Kg

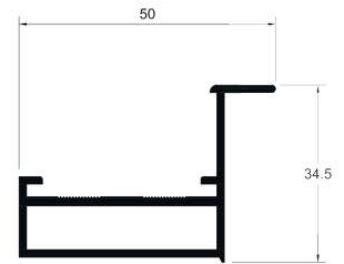

PAT228

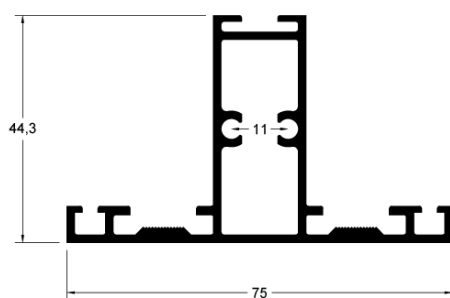

PAT231

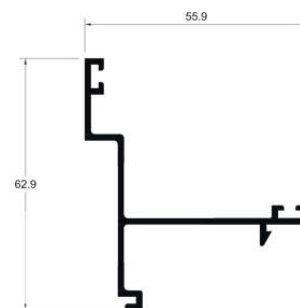

PAT249

LINHA GOLD S/ BAGUETE

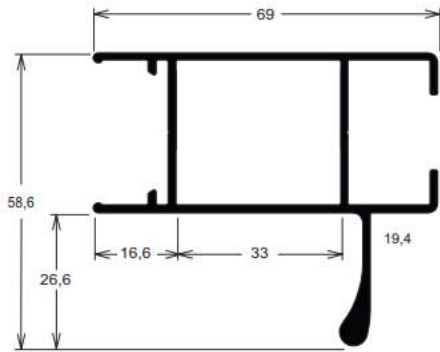

LG126
6,45 Kg

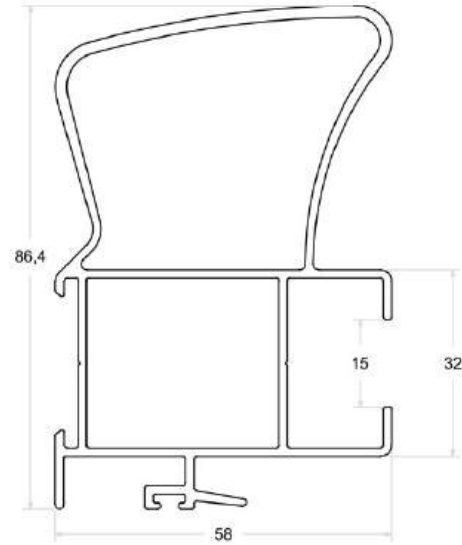

LG127
9,90 Kg

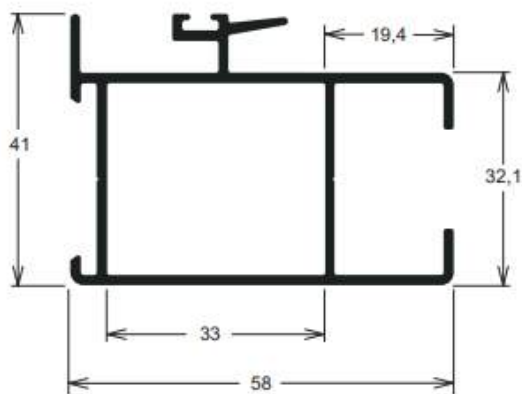

LG128
5,76 Kg

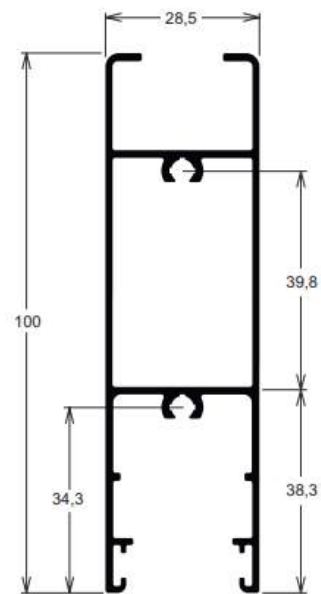

LG129
7 Kg

LINHA GOLD S/ BAGUETE

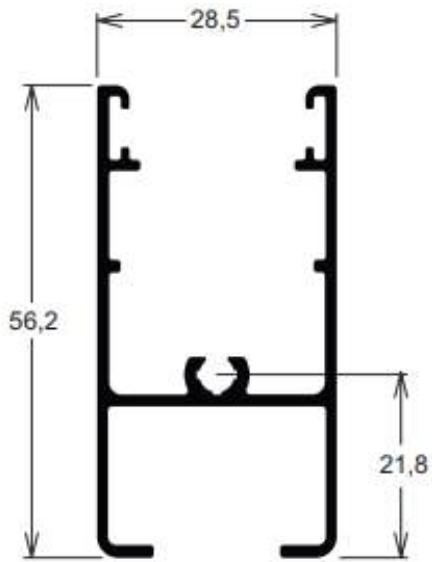

LG130
3,96 Kg

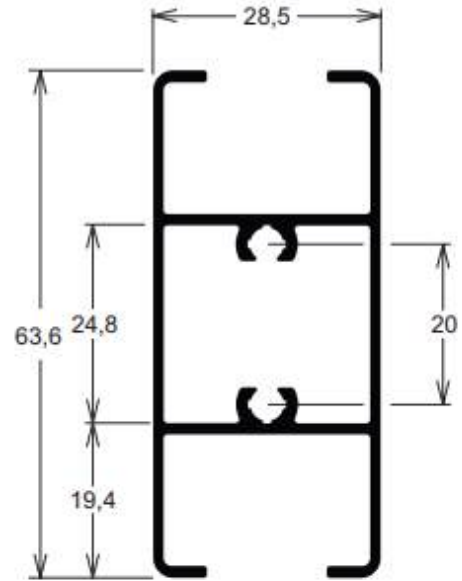

LG131
4,95 Kg

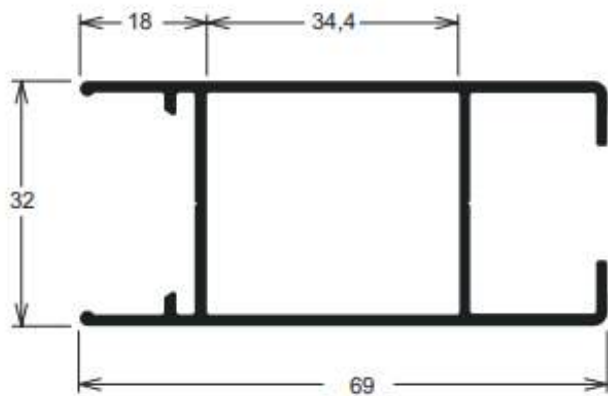

LG132
5,1 Kg

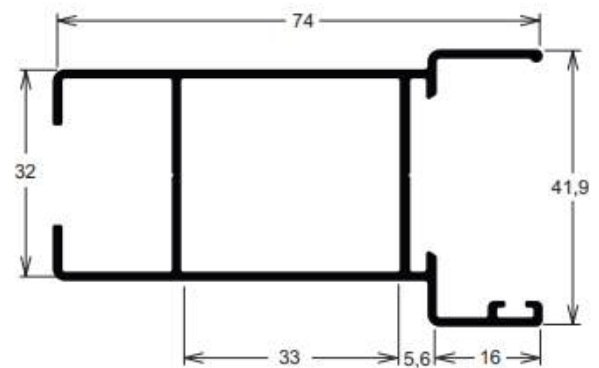

LG133
5,4 Kg

LINHA GOLD

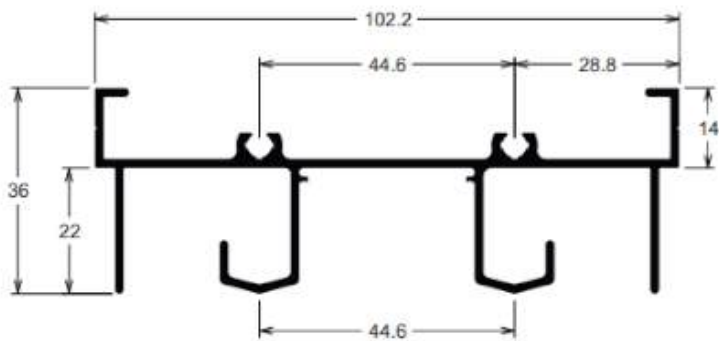

LG044
8,2 Kg

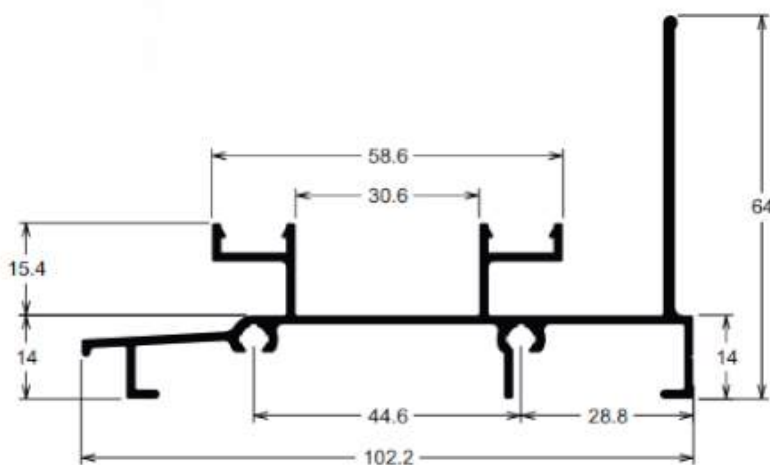

LG115
7,1 Kg

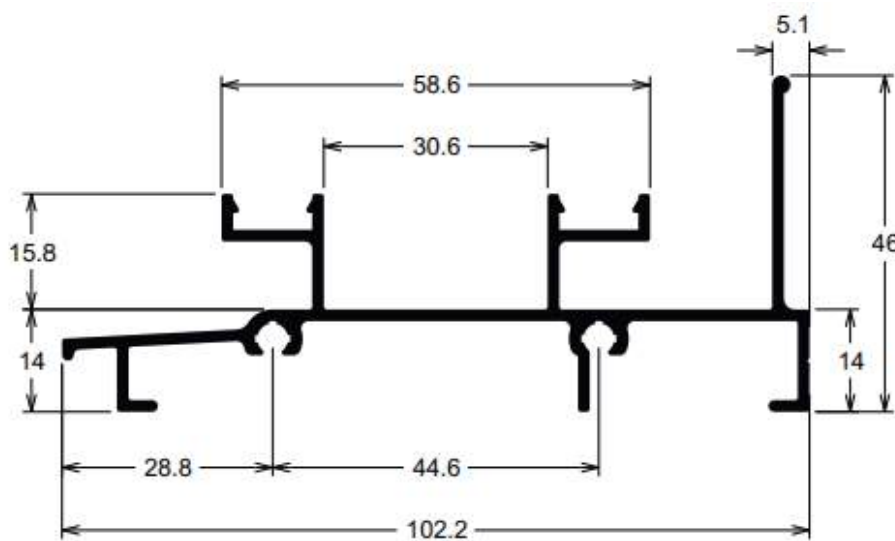

LG159
6,65 Kg



LINHA GOLD

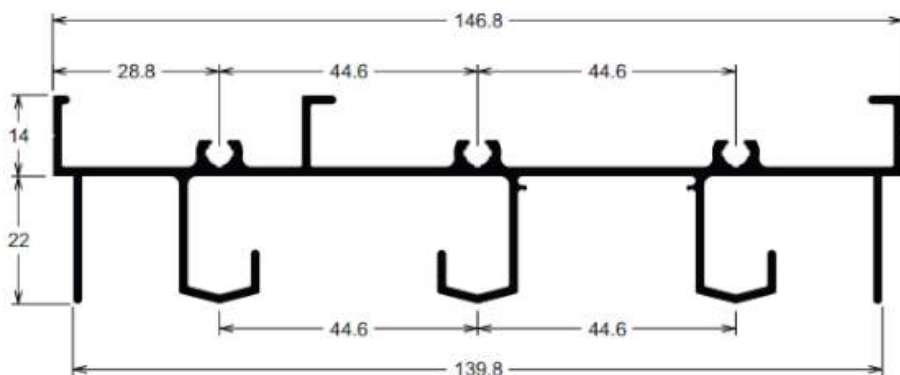

LG062
11,4 Kg

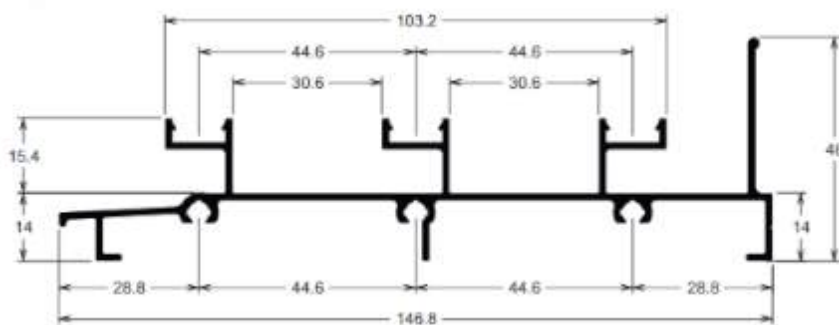

LG116
11,59 Kg

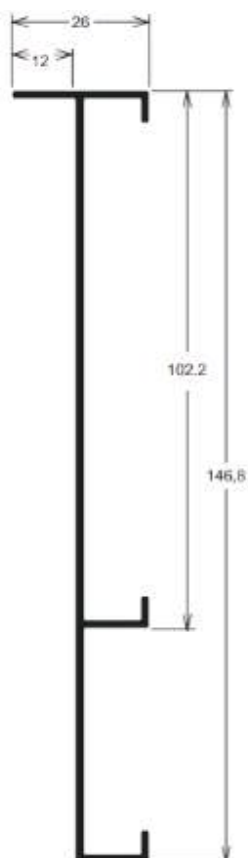

LG158
5,7 Kg

LINHA GOLD

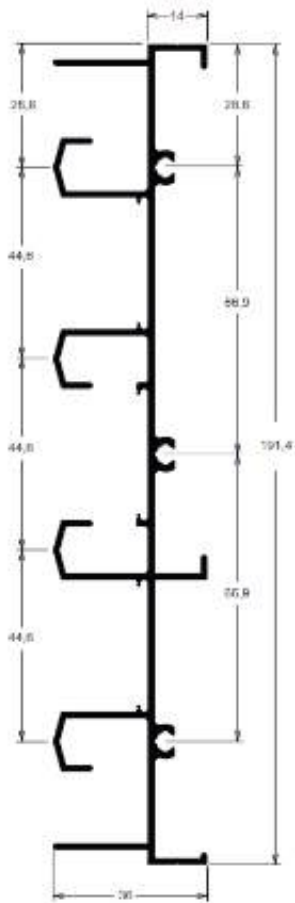

LG070
14,07 Kg

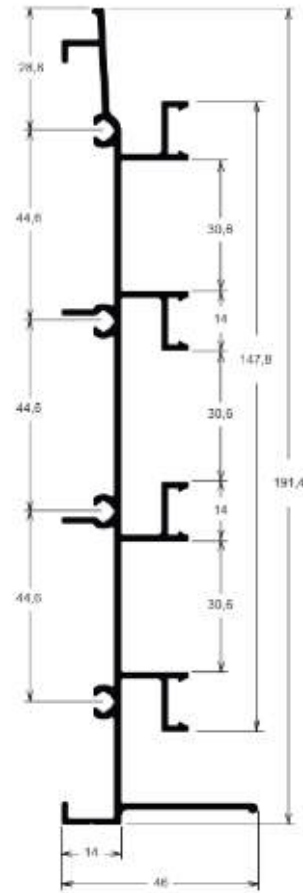

LG160
11,4 Kg

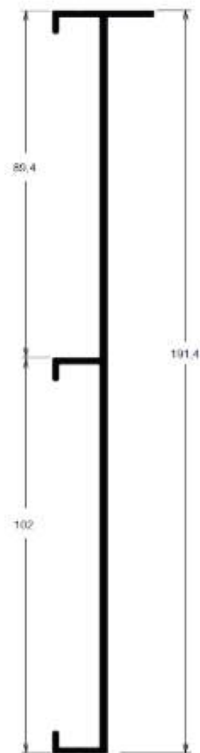

LG072
7,7 Kg

LINHA 30

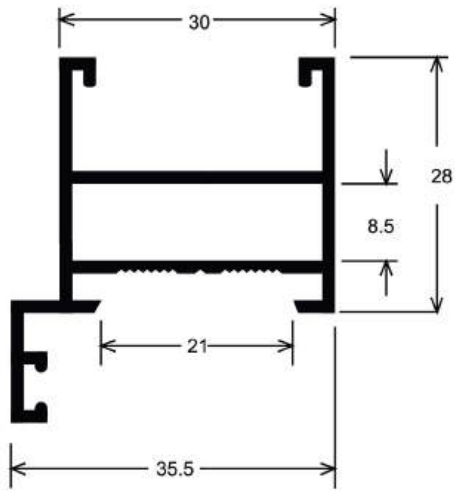

30023
3,53 Kg

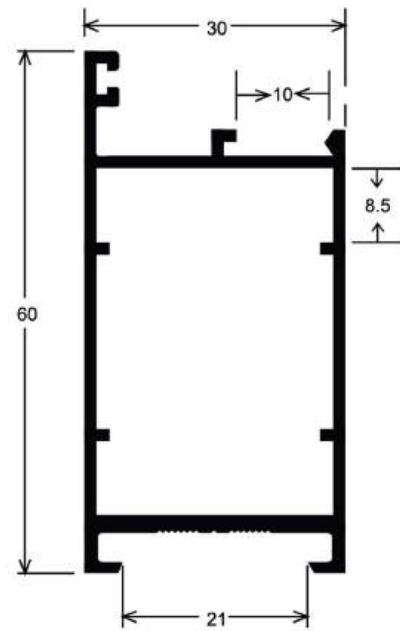

30026
4,7 Kg

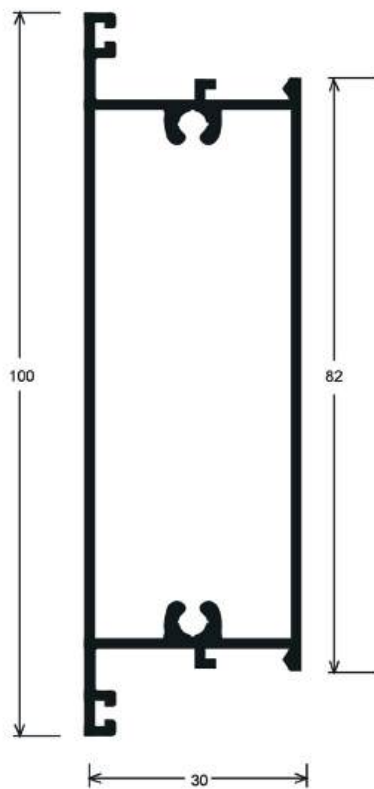

30030
7,95 Kg

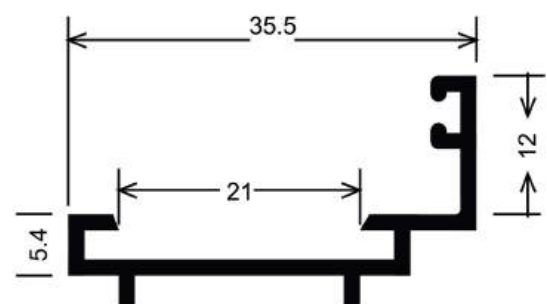

30034
1,8 Kg

LINHA 30

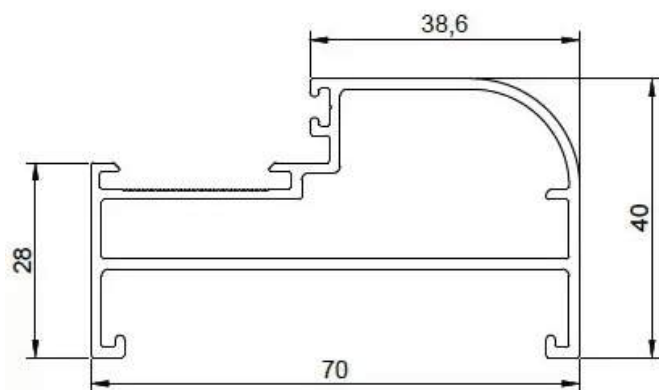

30035
5,47 Kg

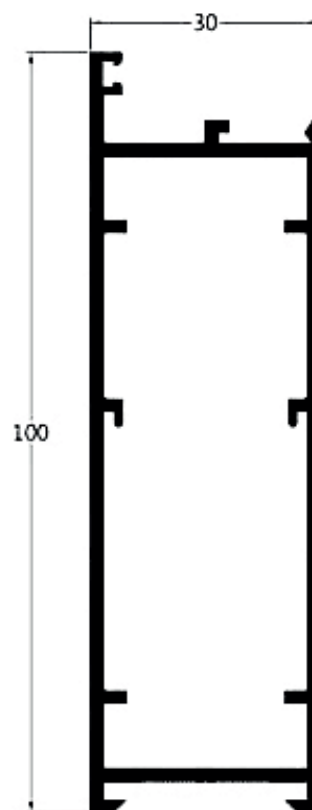

30820
6,9 Kg

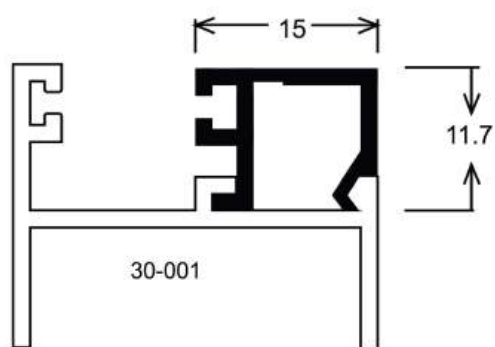

BG010
0,7 Kg

LINHA 30

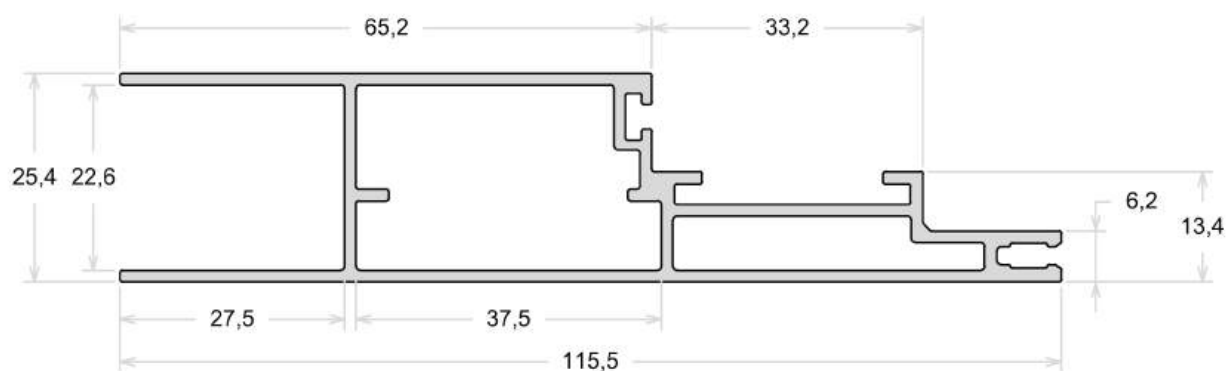

P0001
7,25 Kg

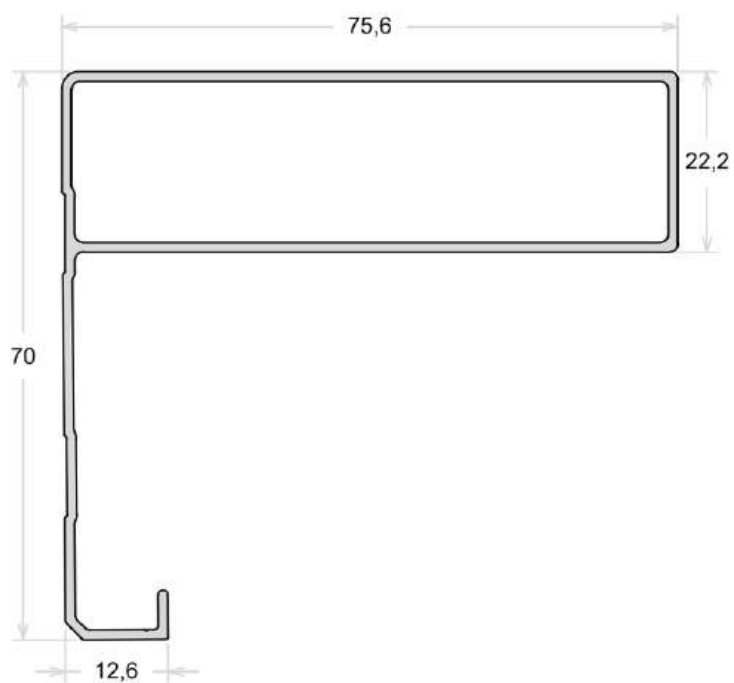

P0003
4,83 Kg

LINHA 30

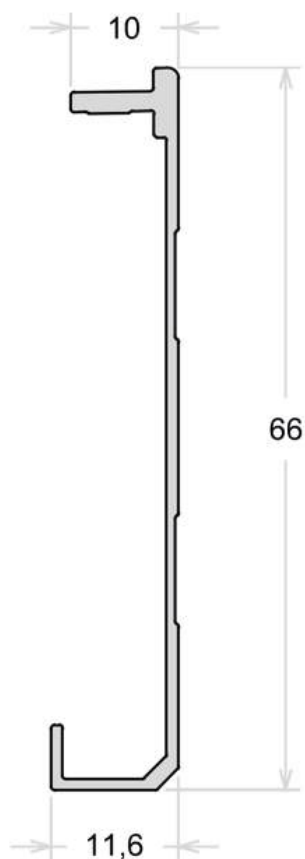

P0002
1,68 Kg

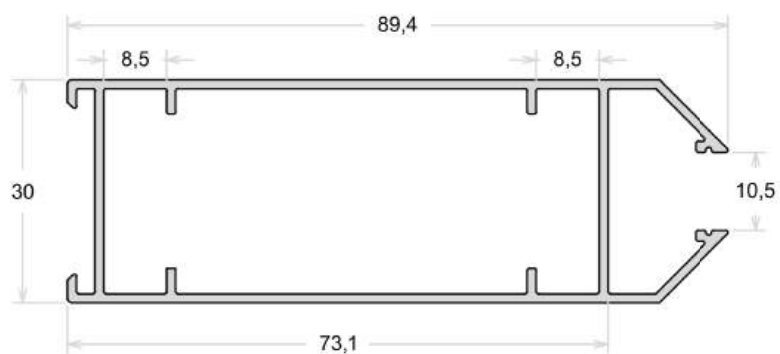

P0004
5,16 Kg



P0008
6,4 Kg

LINHA 32

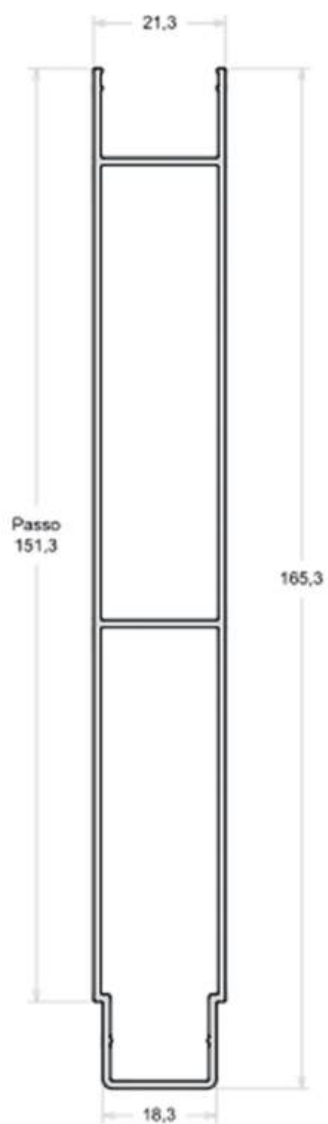

LB080
7,70 Kg

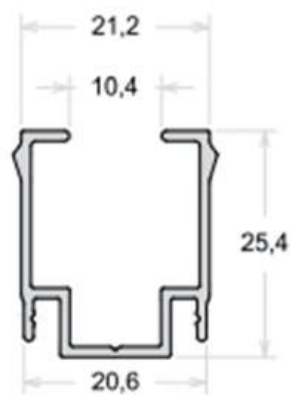

LG238
1,7 Kg

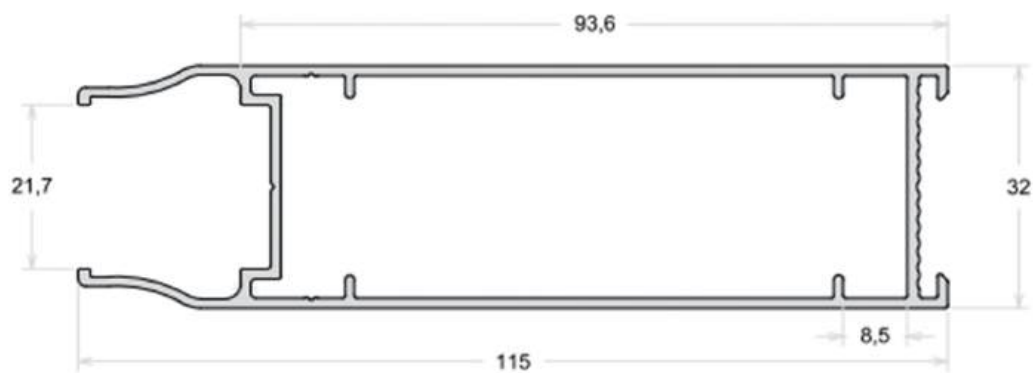

LG239
6,9 Kg

LINHA 32

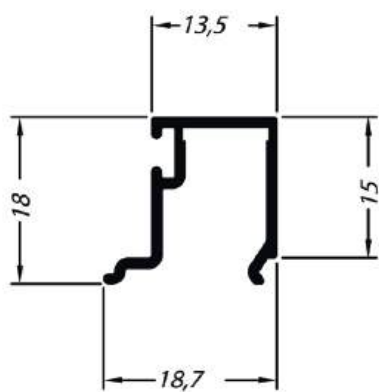

BG057
1,12 Kg



LG002
4,2 Kg

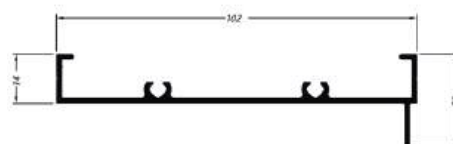

LG003
4,98 Kg

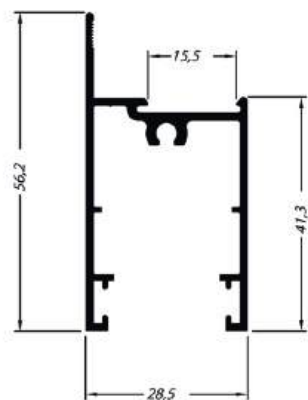

LG006
4,47 Kg

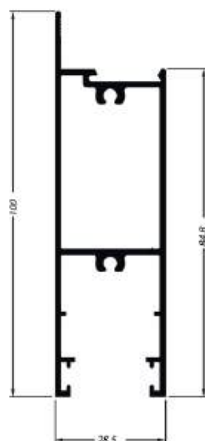

LG007
8,1 Kg

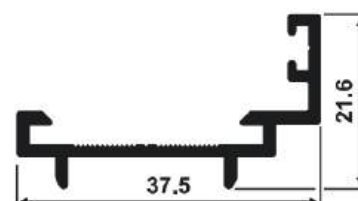

LG016
2,0 Kg

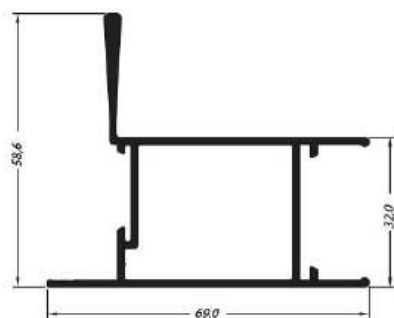

LG017
6,65 Kg

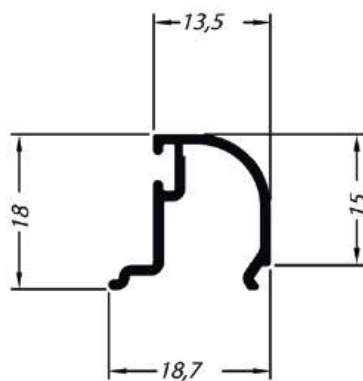

LG026
1,05 Kg

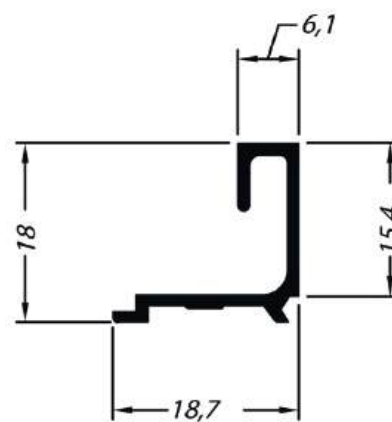

LG027
1 Kg

LINHA 32

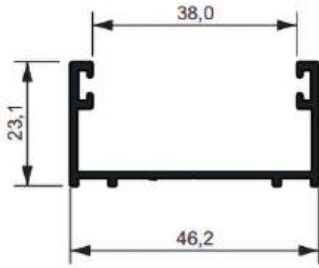

LG028
3 Kg

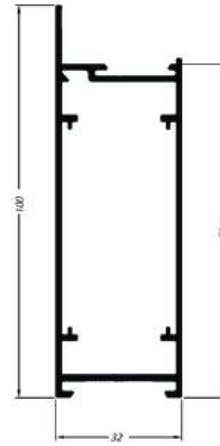

LG042
7,6 Kg

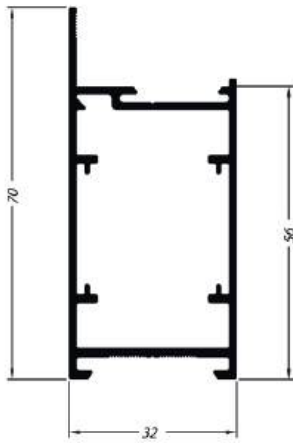

LG043
6,15 Kg

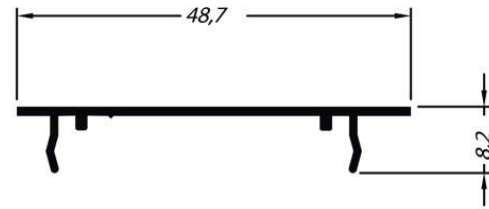

LG046
1,36 Kg

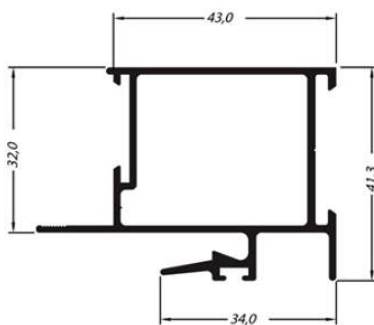

LG048
6,38 Kg

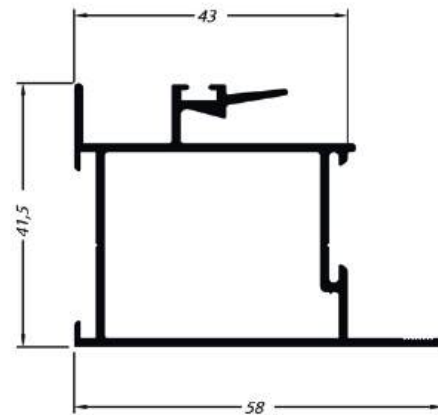

LG049
5,98 Kg

LINHA 32

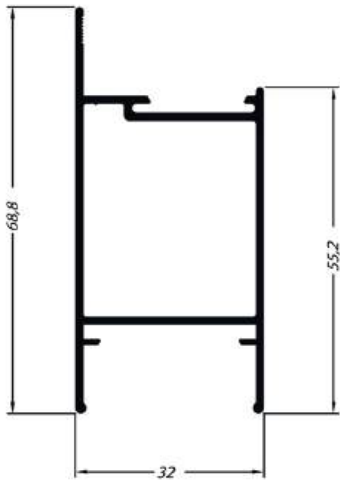

LG050
5,4 Kg

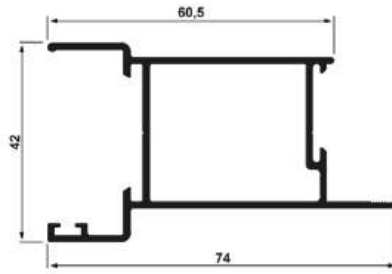

LG051
6,0 Kg

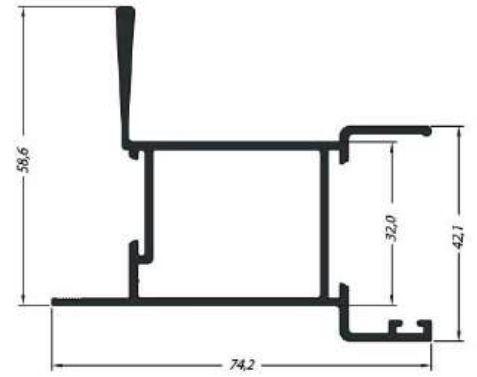

LG020
7,0 Kg

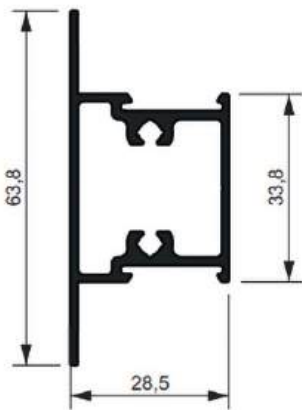

LG055
5 Kg

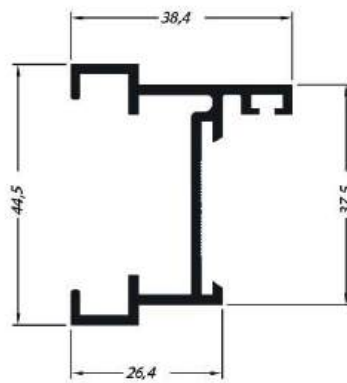

LG056
4,23 Kg

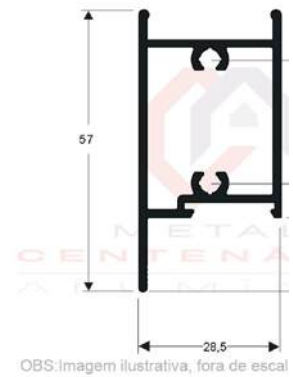

LG058
4,0 Kg

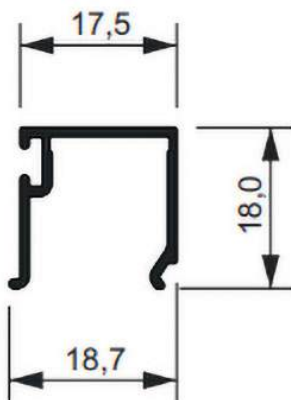

LG059
1,12 Kg

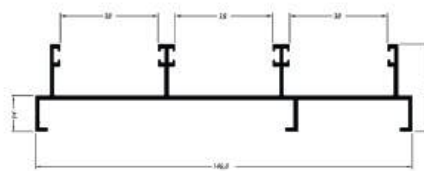

LG064
9 Kg

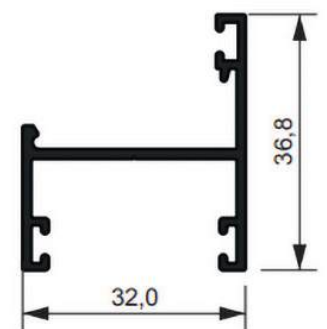

LG068
2,8 Kg

LINHA 32

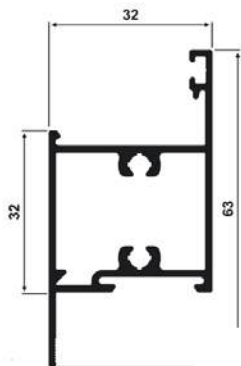

LG076
4,9 Kg

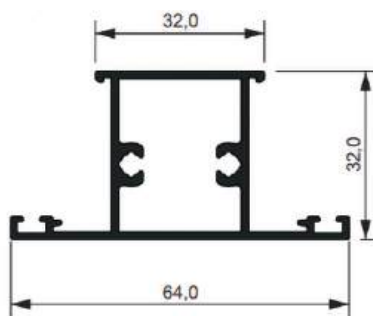

LG074
4,85 Kg

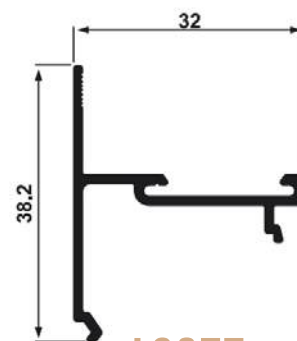

LG077
2,18 Kg

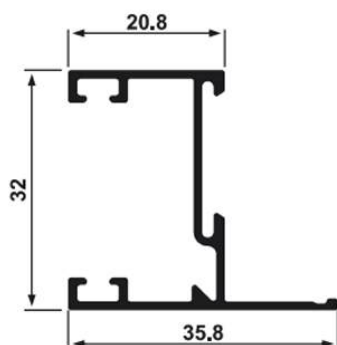

LG083
2,48 Kg

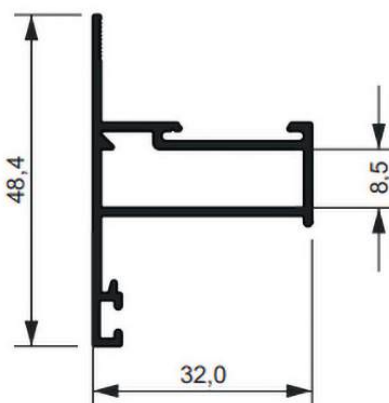

LG085
3,4 Kg

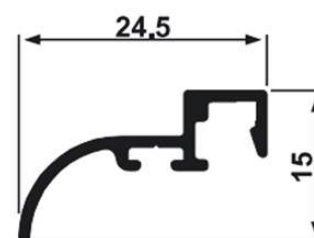

LG091
1,1 Kg

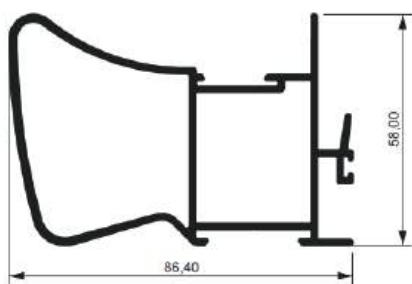

LG137
7,35 Kg - C/ 4,6 MT
9,0 Kg - C/ 6 MT



LG140
7,35 Kg - C/ 4,6 MT
9,0 Kg - C/ 6 MT

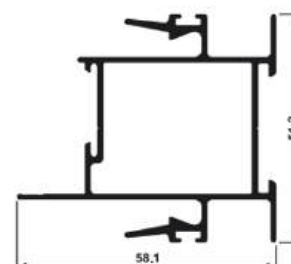

LG162
10 Kg

LINHA 32

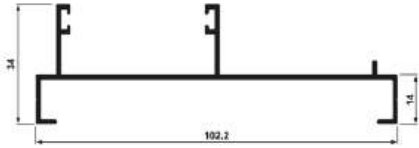

LG124
5,0 Kg

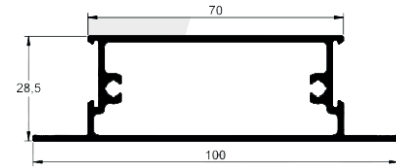

LG022
6,7 Kg | BR

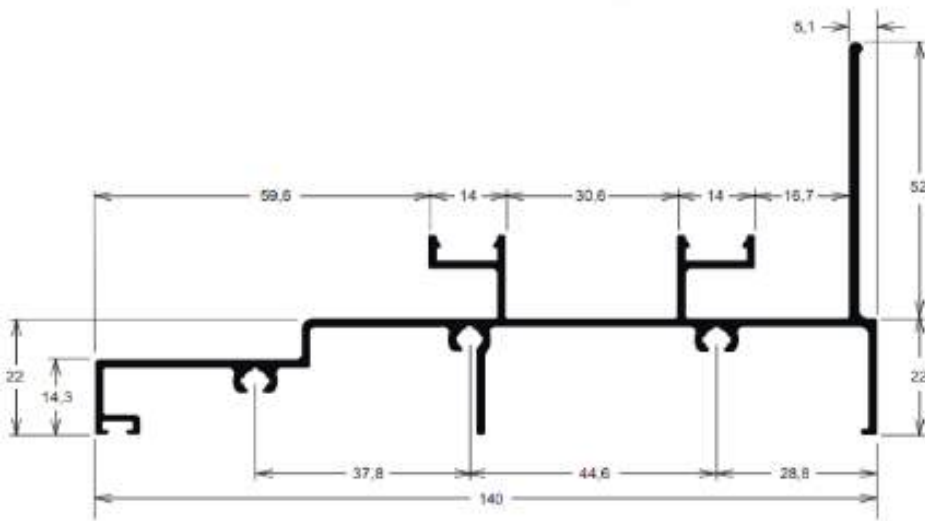

LG172
10,08 Kg

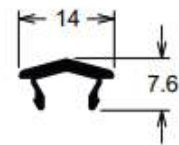

LG111
0,58 Kg

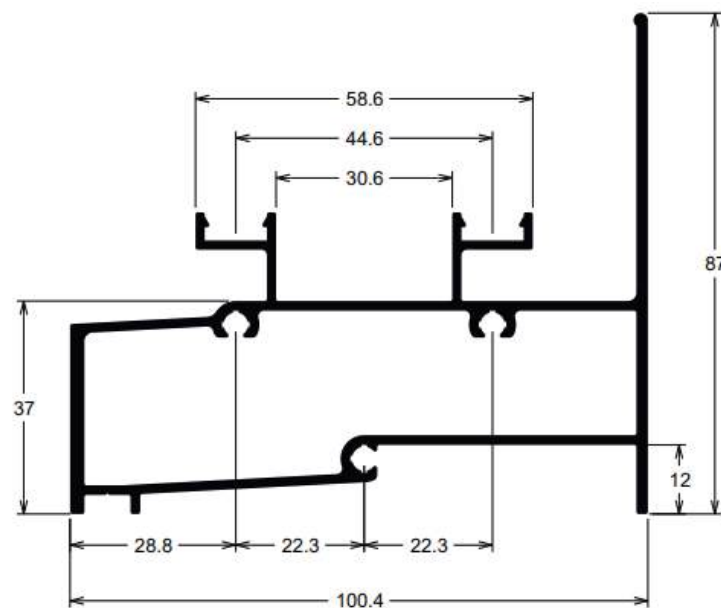

LG117
12 Kg

LINHA INTEGRADA GOLD

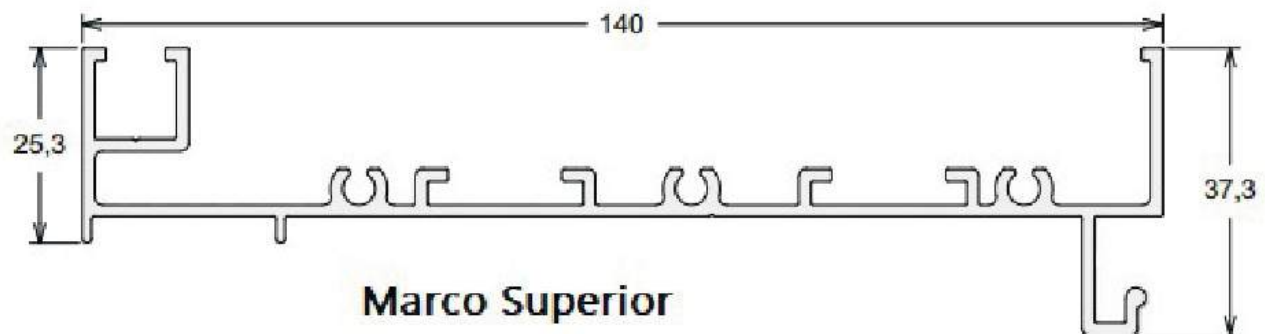

Marco Superior

MN-001

7,90 Kg

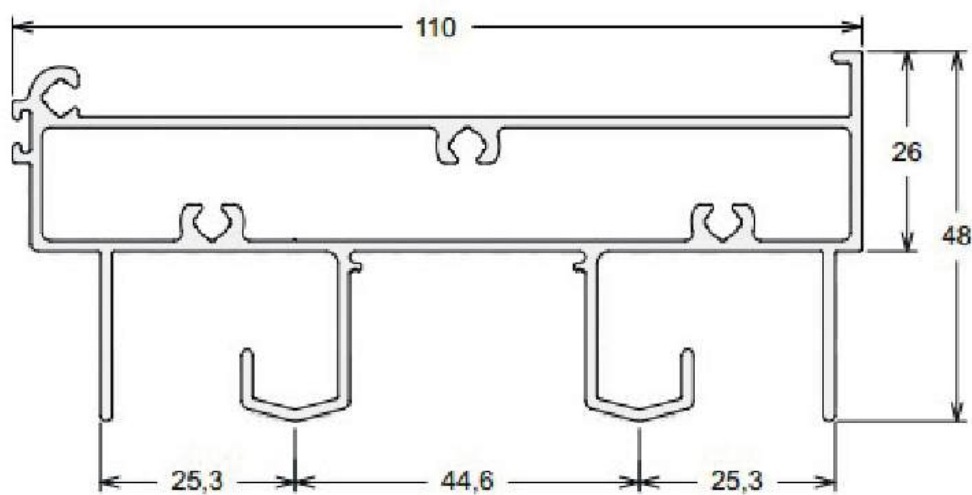

Marco Intermediário

LG-166

10,8 Kg

LINHA INTEGRADA GOLD

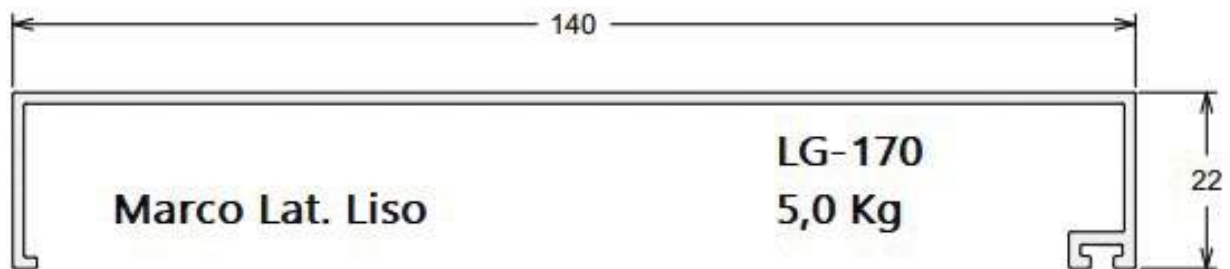
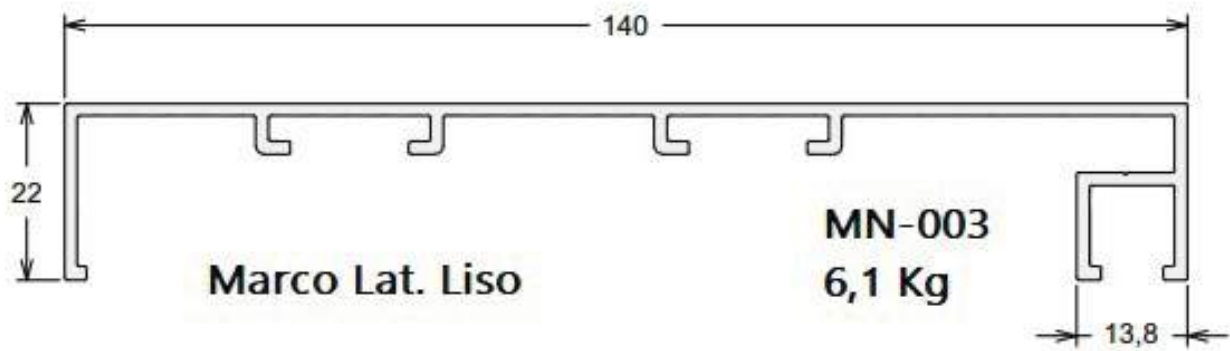

LINHA INTEGRADA GOLD

Tampa Externa

MN-039
7,7 Kg

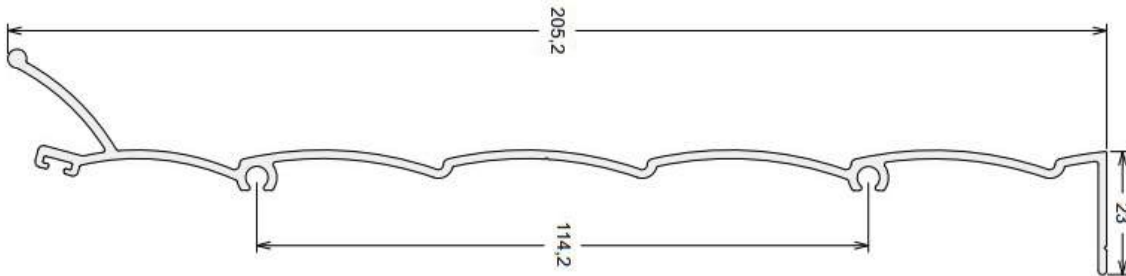

Tampa Interna Grande

MN-032
9,72 Kg



Tampa Interna Pequena

MN-031
7,5 Kg

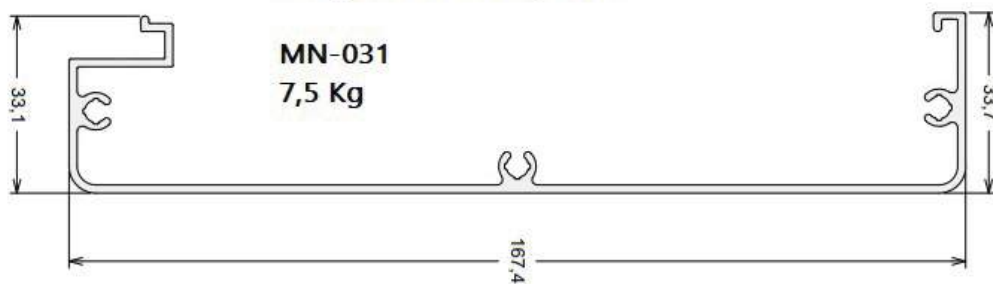

LINHA INTEGRADA GOLD

NOVO!

Marco Superior

LG-168

6,8 Kg

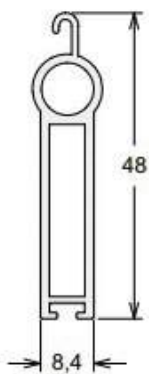
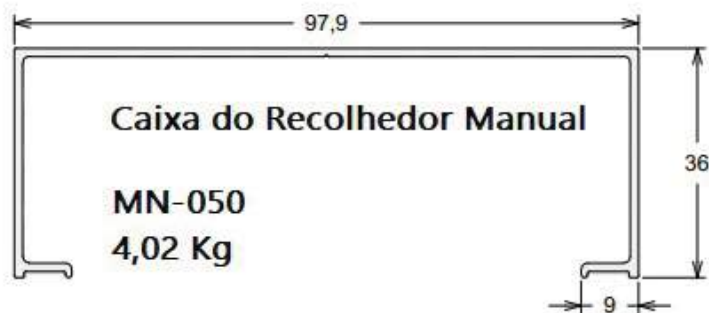
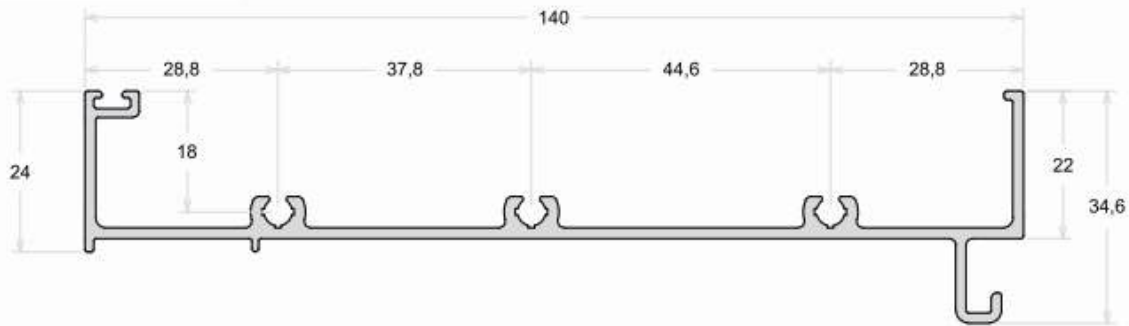

Terminal da Esteira

MN-055

2,5 Kg

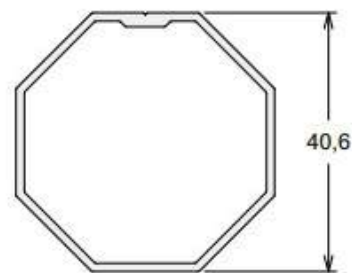

Eixo do Recolhedor 40mm

MN-011

2,9 Kg

FECHAMENTO DE SACADA

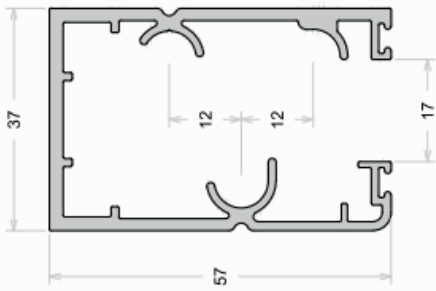

FG011
6,9 Kg

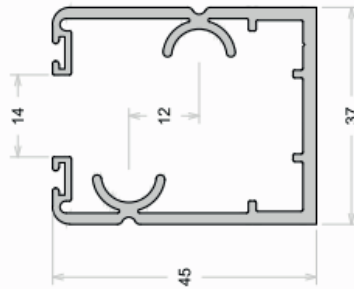

FG002
5,75 Kg

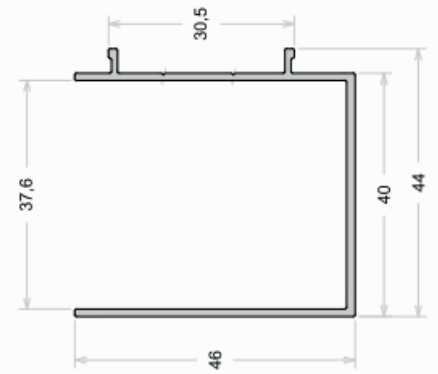

FG007
2,9 Kg

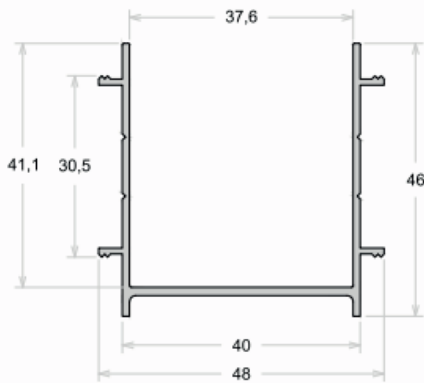

FG009
3,05 Kg

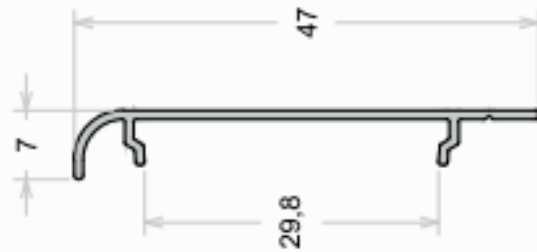

FG004
0,93 Kg

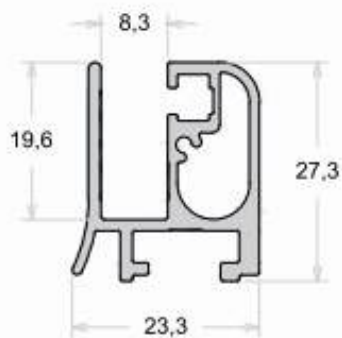

FG008
3,1 Kg

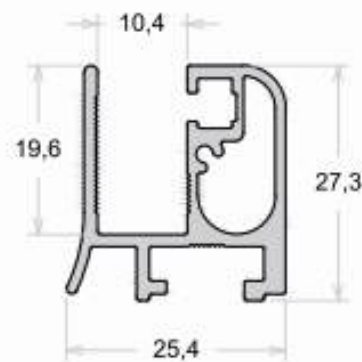

FG010
3,1 Kg

PORTA DE MARCO REGULÁVEL

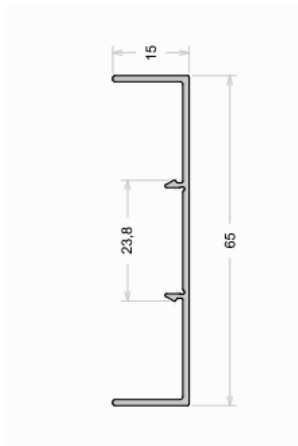

DV013
2 Kg



PMG013
0,49 Kg

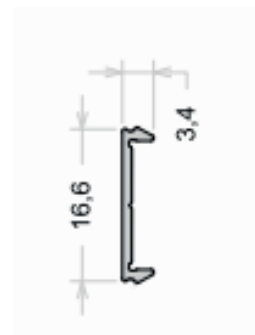

PMG014
0,35 Kg

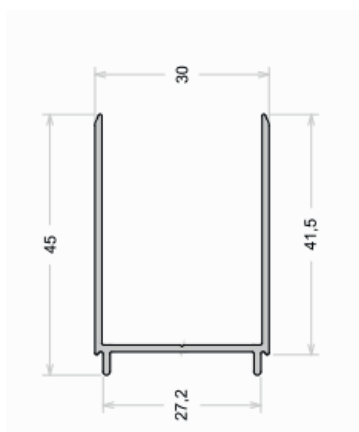

PMG011
2,36 Kg

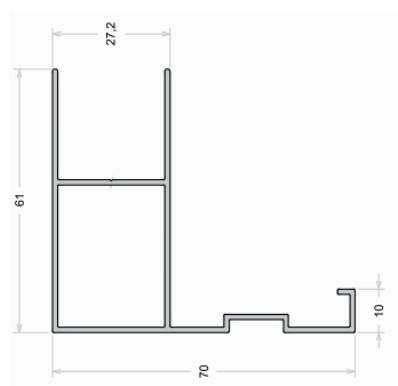

PMG010
4,7 Kg

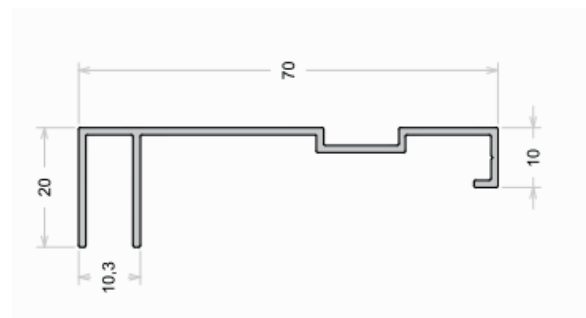

PMG012
2,5 Kg

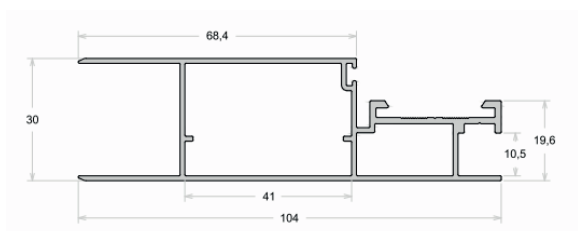

PMG008
6,4 Kg

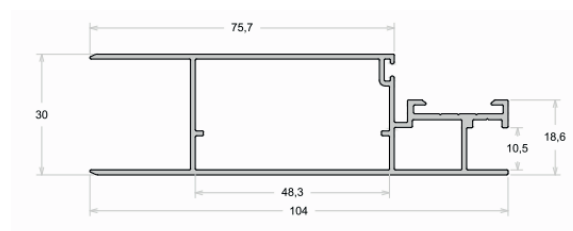

PMG009
6,25 Kg



BLUMENAU:

Rua Guilherme Scharf, 2333
Itoupava Central | CEP 89030-540
(47) 3339-9162 | (47) 3323-9751

CHAPECÓ:

Rua Pequim, 2495
Jardim Europa - Chapecó - SC
CEP 89811-750 | (49) 99185-6414

 @alubendini

 (47) 99611-5319

 bendinialuminios@hotmail.com